

## Operating Instructions

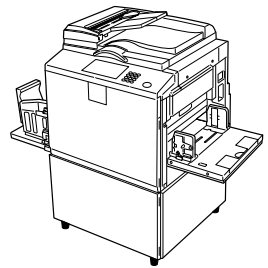

- 
- 1** Before Using the Machine
  - 2** Basics
  - 3** Printing Functions
  - 4** Troubleshooting
  - 5** User Tools
  - 6** Remarks
  - 7** Entering Text
  - 8** Specifications

---

Read this manual carefully before you use this machine and keep it handy for future reference. For safe and correct use, be sure to read the Safety Information before using the machine.

## Introduction

This manual contains detailed instructions and notes on the operation and use of this machine. For your safety and benefit, read this manual carefully before using the machine. Keep this manual in a handy place for quick reference.

## Important

Contents of this manual are subject to change without prior notice. In no event will the company be liable for direct, indirect, special, incidental, or consequential damages as a result of handling or operating the machine.



### Notes:

Some illustrations in this manual might be slightly different from the machine.

Certain options might not be available in some countries. For details, please contact your local dealer.



Two kinds of size notation are employed in this manual. With this machine refer to the metric version.

For good print quality, the supplier recommends that you use genuine master and ink from the supplier.

The supplier shall not be responsible for any damage or expense that might result from the use of parts other than genuine parts from the supplier with your office products.

## Power Source

220 – 240V, 50/60Hz, 1.8A or more

Please be sure to connect the power cord to a power source as above. For details about power source, see p.168 “Power Connection”.

## Trademark

PostScript® and Acrobat® are registered trademarks of Adobe Systems Incorporated.

Other product names used herein are for identification purposes only and might be trademarks of their respective companies. We disclaim any and all rights to those marks.

# Manuals for This Machine

The following manuals describe the operational procedures of this machine. For particular functions, see the relevant parts of the manual.

## **Note**

- Manuals provided are specific to machine type.
- Adobe Acrobat Reader/Adobe Reader is necessary to view the manuals as a PDF file.

## ❖ **Safety Information (paper)**

Describes information about the safety precautions.

## ❖ **Easy Operation Guide (paper/PDF file - CD-ROM \*1)**

Describes information about the control panel and basic operations.

## ❖ **Operating Instructions (this manual)**

Describes operations, functions, User Tools (initial setting, mode setting, etc.) and troubleshooting.

## ❖ **Network Guide (PDF file - CD-ROM \*1)**

Describes procedures for configuring the machine and computers in a network environment.

## ❖ **Printer Reference (PDF file - CD-ROM \*1)**

Describes system settings and operations for the machine's printer function.

## ❖ **Preparations for Use as a Printer (paper/PDF file - CD-ROM \*1)**

Describes procedures for connecting the Ethernet and USB cables to the machine.

## ❖ **Manuals for DeskTopBinder Lite**

DeskTopBinder Lite is a utility included on the CD-ROM labeled "Document Management Utility".

- DeskTopBinder Lite Setup Guide (PDF file - CD-ROM \*2)  
Describes the installation of, and the operating environment for DeskTopBinder Lite in detail. This guide can be displayed from the **[Setup]** dialog box when DeskTopBinder Lite is installed.
- DeskTopBinder Introduction Guide (PDF file - CD-ROM \*2)  
Describes operations of DeskTopBinder Lite and provides an overview of its functions. This guide is added to the **[Start]** menu when DeskTopBinder Lite is installed.

## ❖ **Other manuals**

- PostScript3 (PDF file - CD-ROM \*1)

\*1 Provided on the CD-ROM labeled "Operating Instructions"

\*2 Provided on the CD-ROM labeled "Document Management Utility"

# What You Can do with this Machine

Below is a quick summary of this machine's features and where to look for more information.

❖ **Basic Procedure**

See p.44 "Basic Procedure".

❖ **Saving Energy**

See p.46 "Saving Energy".

❖ **Printing onto Various Kinds of Paper**

See p.47 "Printing onto Various Kinds of Paper".

❖ **Image Rotation**

See p.51 "Image Rotation".

❖ **Selecting Original Type**

See p.52 "Selecting Original Type".

❖ **Master Making Density**

See p.53 "Master Making Density".

❖ **Adjusting the Position of Printed Images**

See p.54 "Adjusting the Position of Printed Images".

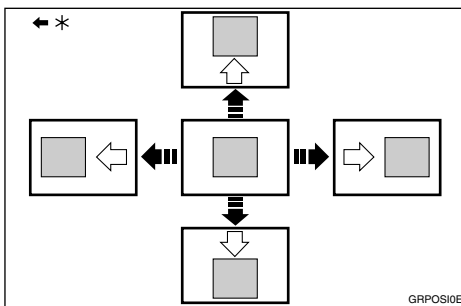

\*Paper feed direction

❖ **Changing the Printing Speed**

See p.55 "Changing the Printing Speed".

❖ **Preset Reduce/Enlarge**

See p.57 "Preset Reduce/Enlarge".

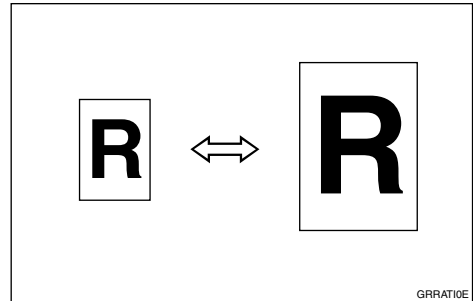

❖ **Zoom**

See p.58 "Zoom".

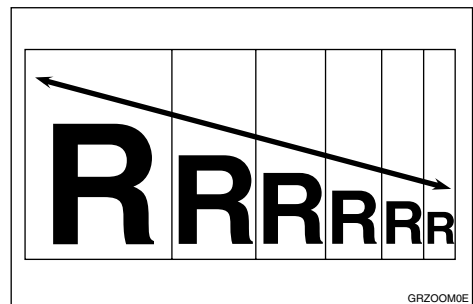

❖ **Auto Reduce/Enlarge**

See p.59 "Auto Reduce/Enlarge".

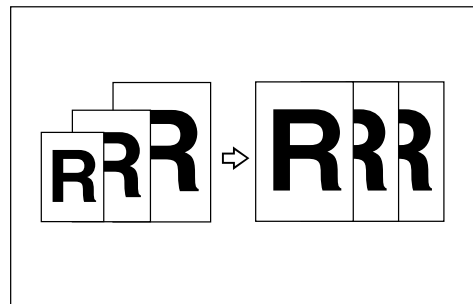

❖ **Directional Magnification (%)**

See p.61 “Directional Magnification (%)”.

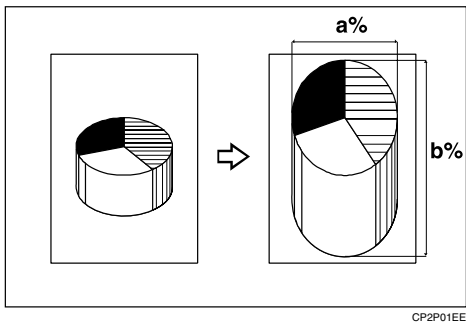

❖ **Class Settings**

See p.67 “Class Settings”.

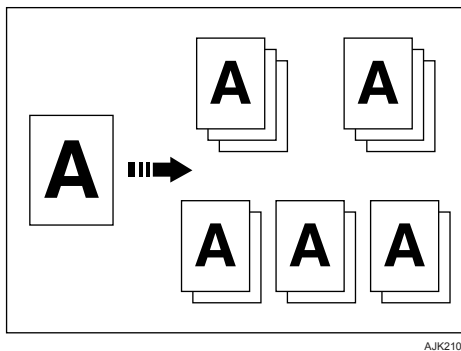

❖ **Directional Size Magnification (mm)**

See p.62 “Directional Size Magnification (mm)”.

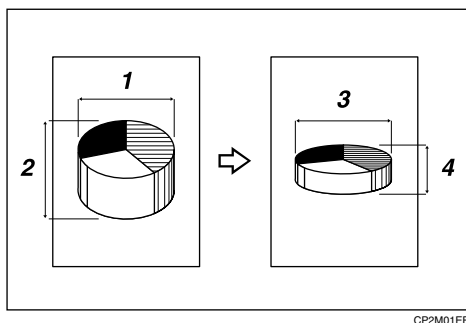

❖ **Separate**

See p.71 “Separate”.

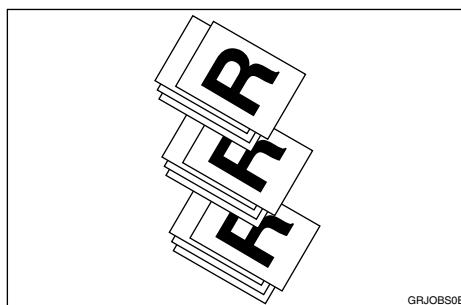

❖ **Combine**

See p.63 “Combine”.

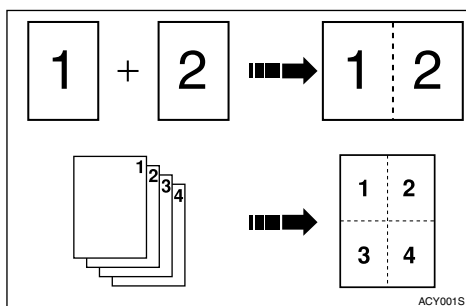

❖ **Image Repeat**

See p.73 “Image Repeat”.

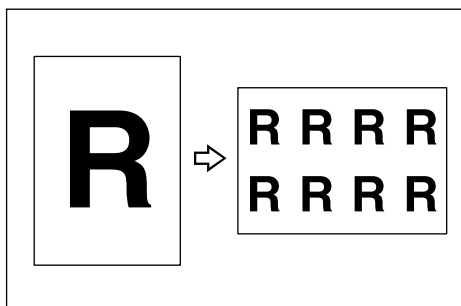

❖ **Centring**

See p.76 “Centring”.

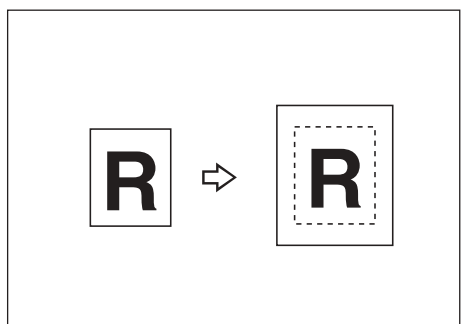

❖ **Erase Border**

See p.76 “Erase Border”.

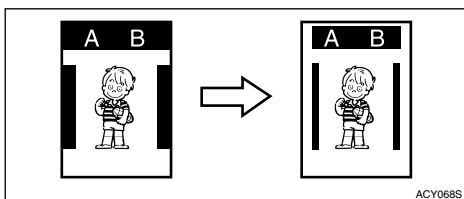

❖ **Margin Adjustment**

See p.77 “Margin Adjustment”.

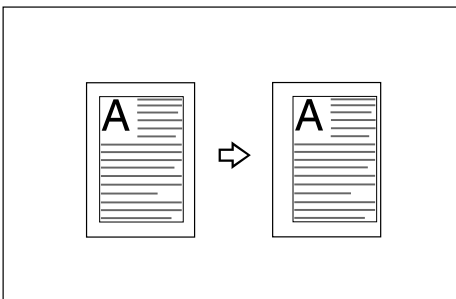

❖ **Overlay**

See p.78 “Overlay”.

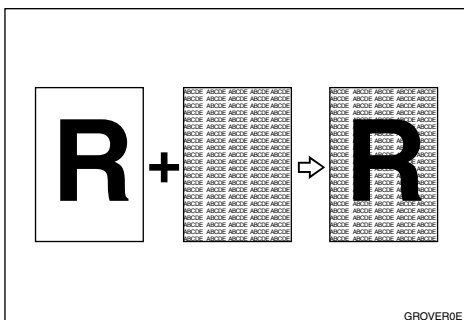

❖ **Preset Stamp**

See p.80 “Preset Stamp”.

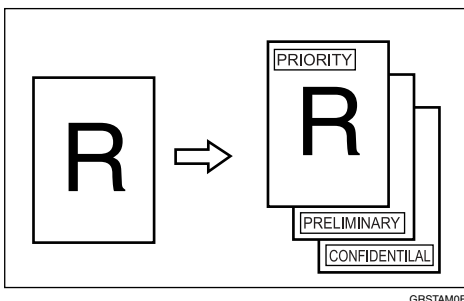

❖ **Make-up**

See p.82 “Make-Up Printing Features”, p.85 “Command Sheets for Make-Up Printing”, and p.92 “Make-Up Printing”.

❖ **Quality Start**

See p.95 “Quality Start”.

❖ **Economy Mode**

See p.96 “Economy Mode”.

❖ **Skip Feed**

See p.96 “Skip Feed”.

❖ **Security**

See p.97 “Security”.

❖ **Conserving the Master**

See p.98 “Conserving the Master”.

❖ **Double Feed**

See p.99 “Double Feed”.

❖ **Storing File**

See p.100 “Storing File”.

❖ **Programs**

See p.106 “Programs”.

❖ **Making Colour Prints**

See p.109 “Making Colour Prints”.

❖ **Changing the Drum Size**

See p.113 “Changing the Drum Size”.

❖ **Printing from the computer**

See *Printer Reference*.

# TABLE OF CONTENTS

<b>Manuals for This Machine</b> .....	<b>i</b>
<b>What You Can do with this Machine</b> .....	<b>ii</b>
<b>Notice</b> .....	<b>1</b>
Information about Installed Software .....	1
<b>How to Read This Manual</b> .....	<b>7</b>
<b>Safety Information</b> .....	<b>8</b>
Safety During Operation .....	8
<b>Positions of ⚠WARNING and ⚠CAUTION Labels</b> .....	<b>10</b>
<b>Guide To Components</b> .....	<b>11</b>
<b>Options</b> .....	<b>14</b>
Option List .....	14
Guide to Major Options .....	15
<b>Control Panel</b> .....	<b>17</b>
Display Panel .....	19
<b>Turning On the Power</b> .....	<b>21</b>
Turning On the Power .....	21
Turning Off the Power .....	21

## 1. Before Using the Machine

---

<b>Originals</b> .....	<b>23</b>
Size and Weights of Recommended Originals .....	23
Sizes difficult to detect .....	25
<b>Print Paper</b> .....	<b>26</b>
Recommended Paper Size and Type .....	26
Recommended for the LCIT .....	26
Recommended for the LCOT .....	27
Non-recommended Paper .....	27
Storing Paper .....	29
<b>Printing Size</b> .....	<b>30</b>

## 2. Basics

---

<b>Printing Preparations</b> .....	<b>31</b>
Using the Paper Feed Tray and Delivery Tray .....	31
Using the LCIT and LCOT .....	34
<b>After Printing</b> .....	<b>39</b>
Folding the Paper Feed Tray and Delivery Tray .....	39
Uninstalling the LCIT .....	41
<b>Placing Originals</b> .....	<b>42</b>
Original Orientation .....	42
Placing Originals on the Exposure Glass .....	43
Placing Originals in the Auto Document Feeder .....	43
<b>Basic Procedure</b> .....	<b>44</b>
Original Beeper .....	45
Auto Reset .....	45
Saving Energy .....	46
Auto Off Timer .....	46

<b>Printing onto Various Kinds of Paper</b> .....	<b>47</b>
Printing onto Thick Paper .....	47
Printing onto Standard Paper .....	47
Printing onto Envelopes .....	47
Printing onto Special Paper .....	48
<b>Making a Master and Prints</b> .....	<b>49</b>
Selecting Cycle Setting .....	50
Image Rotation .....	51
Selecting Original Type .....	52
Master Making Density .....	53
<b>Sample Print and Adjustment</b> .....	<b>54</b>
Adjusting the Position of Printed Images .....	54
Changing the Printing Speed .....	55

### 3. Printing Functions

---















<b>Printing Functions</b> .....	<b>57</b>
Preset Reduce/Enlarge .....	57
Zoom .....	58
Auto Reduce/Enlarge .....	59
Directional Magnification (%) .....	61
Directional Size Magnification (mm) .....	62
Combine .....	63
Class Settings .....	67
Separate .....	71
Image Repeat .....	73
Centring .....	76
Erase Border .....	76
Margin Adjustment .....	77
Overlay .....	78
Preset Stamp .....	80
Make-Up Printing Features .....	82
Command Sheets for Make-Up Printing .....	85
Make-Up Printing .....	92
Quality Start .....	95
Economy Mode .....	96
Skip Feed .....	96
Security .....	97
Conserving the Master .....	98
Double Feed .....	99
<b>Storing File</b> .....	<b>100</b>
Storing Data .....	100
Changing a Stored File's User Name, File Name, or Password .....	102
Searching for Stored Files .....	103
Printing Stored Files .....	104
Deleting Stored Files .....	105
Printing or Deleting Stored Files Using a Web Browser .....	105



<b>Programs</b> .....	<b>106</b>
Storing a Program .....	106
Recalling a Program.....	107
Changing a Stored Program .....	107
Changing a Program Name .....	107
Protecting a Program .....	107
Deleting a Program .....	108
<b>Making Colour Prints</b> .....	<b>109</b>
Changing the Colour Drum Unit.....	109
Making Colour Prints.....	110
Printing in Two Colours .....	111
<b>Changing the Drum Size</b> .....	<b>113</b>
Printing Area (At 23°C/73°F, 65% RH).....	113
Master Cut Length.....	113
<b>Combination Chart</b> .....	<b>114</b>

## 4. Troubleshooting

---

<b>If Your Machine Does Not Operate as You Want</b> .....	<b>117</b>
<b>If you Cannot Make Clear Prints</b> .....	<b>119</b>
Faint Prints .....	119
Black Lines/Stained Prints .....	119
Dirty Background.....	119
<b>If You Cannot Make Prints as You Want</b> .....	<b>122</b>
Combine.....	122
Storing Files .....	123
 <b>Loading Paper</b> .....	<b>124</b>
Loading Paper into the Paper Feed Tray .....	124
Loading Paper into LCIT .....	125
 <b>Adding Ink</b> .....	<b>126</b>
 <b>Replacing the Master Roll</b> .....	<b>128</b>
 <b>Clearing Misfeeds</b> .....	<b>130</b>
“  + A” Paper Misfeeds in the Paper Feed Section.....	130
”  + A + B” Paper Misfeeds in the Paper Feed Section .....	131
“  + B” Paper or Master Wrapped Around the Drum.....	132
“  + C” Paper Misfeeds in the Paper Exit Section.....	135
“  + D” Master Misfeeds in the Master Feed Section.....	135
“  + B + D” Master Misfeeds in the Master Feed Section .....	136
“  + B + E” Master Misfeeds in the Master Eject Section.....	137
“  + E” Master Misfeeds in the Master Eject Section .....	138
“  + P” Original Misfeeds Occur in the Auto Document Feeder.....	139
When Paper Misfeeds in the LCIT .....	140
<b>Changing the Paper Size</b> .....	<b>141</b>
Changing the Paper Size of the Paper Feed Tray .....	141
Changing the Paper Size of LCIT .....	142
 <b>When the Open Cover/Unit Indicator Lights</b> .....	<b>143</b>
 <b>Removing the Used Master</b> .....	<b>144</b>
<b>When Multiple Sheets Are Fed at the Same Time</b> .....	<b>145</b>
<b>When Prints Are Not Delivered in a Neat Stack</b> .....	<b>146</b>
When Printing on Small Size Paper .....	146

## 5. User Tools

---

<b>User Tools Menu</b> .....	<b>147</b>
System Settings .....	147
Master Making/Print Settings .....	149
<b>Accessing User Tools (System Settings/Master Making/Print Settings).....</b>	<b>152</b>
Changing Default Settings .....	152
Quitting User Tools .....	152
<b>Settings You Can Change with User Tools .....</b>	<b>153</b>
System Settings .....	153
Master Making/Print Settings .....	158
<b>User Code</b> .....	<b>162</b>
Registering a User Code .....	162
Changing a User Code.....	163
Deleting a User Code .....	163
Displaying the Counter for Each User Code .....	163
Printing the Counter for All User Codes .....	164
Clearing the Counter .....	164

## 6. Remarks

---

<b>Do's and Don'ts</b> .....	<b>165</b>
<b>Where to Put Your Machine</b> .....	<b>167</b>
Machine Environment .....	167
Moving.....	168
Power Connection.....	168
Access to the Machine .....	169
<b>Maintaining Your Machine</b> .....	<b>170</b>
Cleaning the Exposure Glass.....	170
Cleaning the exposure glass cover .....	170
Cleaning the Auto Document Feeder.....	171
Cleaning the paper feed roller (paper feed tray) .....	171
Cleaning the paper feed roller (LCIT).....	171
<b>Other Functions</b> .....	<b>172</b>
Inquiry .....	172
Changing the Display Language .....	173
<b>Counter/Data Print</b> .....	<b>174</b>
Displaying the Counter .....	174
Print the log data and programmed class list .....	174

## 7. Entering Text

---

<b>Entering Text</b> .....	<b>175</b>
Available Characters .....	175
Keys .....	175
Entering Text.....	176

## 8. Specifications

---

<b>Main Unit</b> .....	<b>177</b>
<b>Options</b> .....	<b>180</b>
Auto Document Feeder (ADF: DF Type 85).....	180
Twin Colour Press Roller Printing System TC-IIR.....	181
Large Capacity System (LCS: LS3000R).....	182
Other Options.....	183
<b>Consumables</b> .....	<b>184</b>
<b>INDEX</b> .....	<b>185</b>



# Notice

---

## Important

---

Do not copy or print any item for which reproduction is prohibited by law.

Copying or printing the following items is generally prohibited by local law:

bank notes, revenue stamps, bonds, stock certificates, bank drafts, checks, passports, driver's licenses.

The preceding list is meant as a guide only and is not inclusive. We assume no responsibility for its completeness or accuracy. If you have any questions concerning the legality of copying or printing certain items, consult with your legal advisor.

---

## Information about Installed Software

---

---

### expat

---

- The software including controller, etc. (hereinafter “software”) installed on this product uses the expat Version 1.95.2 (hereinafter “expat”) under the conditions mentioned below.
- The product manufacturer provides warranty and support to the software of the product including the expat, and the product manufacturer makes the initial developer and copyright holder of the expat, free from these obligations.
- Information relating to the expat is available at:  
<http://expat.sourceforge.net/>

Copyright (c) 1998, 1999, 2000 Thai Open Source Software Centre, Ltd. and Clark Cooper.

Permission is hereby granted, free of charge, to any person obtaining a copy of this software and associated documentation files (the “Software”), to deal in the Software without restriction, including without limitation the rights to use, copy, modify, merge, publish, distribute, sublicense, and/or sell copies of the Software, and to permit persons to whom the Software is furnished to do so, subject to the following conditions:

The above copyright notice and this permission notice shall be included in all copies or substantial portions of the Software.

THE SOFTWARE IS PROVIDED “AS IS”, WITHOUT WARRANTY OF ANY KIND, EXPRESS OR IMPLIED, INCLUDING BUT NOT LIMITED TO THE WARRANTIES OF MERCHANTABILITY, FITNESS FOR A PARTICULAR PURPOSE AND NONINFRINGEMENT. IN NO EVENT SHALL THE AUTHORS OR COPYRIGHT HOLDERS BE LIABLE FOR ANY CLAIM, DAMAGES OR OTHER LIABILITY, WHETHER IN AN ACTION OF CONTRACT, TORT OR OTHERWISE, ARISING FROM, OUT OF OR IN CONNECTION WITH THE SOFTWARE OR THE USE OR OTHER DEALINGS IN THE SOFTWARE.

## 1. Copyright Notice of NetBSD

For all users to use this product:

This product contains NetBSD operating system:

For the most part, the software constituting the NetBSD operating system is not in the public domain; its authors retain their copyright.

The following text shows the copyright notice used for many of the NetBSD source code. For exact copyright notice applicable for each of the files/binaries, the source code tree must be consulted.

A full source code can be found at <http://www.netbsd.org/>.

Copyright © 1999, 2000 The NetBSD Foundation, Inc.

All rights reserved.

Redistribution and use in source and binary forms, with or without modification, are permitted provided that the following conditions are met:

- ① Redistributions of source code must retain the above copyright notice, this list of conditions and the following disclaimer.
- ② Redistributions in binary form must reproduce the above copyright notice, this list of conditions and the following disclaimer in the documentation and/or other materials provided with the distribution.
- ③ All advertising materials mentioning features or use of this software must display the following acknowledgment:  
This product includes software developed by The NetBSD Foundation, Inc. and its contributors.
- ④ Neither the name of The NetBSD Foundation nor the names of its contributors may be used to endorse or promote products derived from this software without specific prior written permission.

THIS SOFTWARE IS PROVIDED BY THE NETBSD FOUNDATION, INC. AND CONTRIBUTORS "AS IS" AND ANY EXPRESS OR IMPLIED WARRANTIES, INCLUDING, BUT NOT LIMITED TO, THE IMPLIED WARRANTIES OF MERCHANTABILITY AND FITNESS FOR A PARTICULAR PURPOSE ARE DISCLAIMED. IN NO EVENT SHALL THE FOUNDATION OR CONTRIBUTORS BE LIABLE FOR ANY DIRECT, INDIRECT, INCIDENTAL, SPECIAL, EXEMPLARY, OR CONSEQUENTIAL DAMAGES (INCLUDING, BUT NOT LIMITED TO, PROCUREMENT OF SUBSTITUTE GOODS OR SERVICES; LOSS OF USE, DATA, OR PROFITS; OR BUSINESS INTERRUPTION) HOWEVER CAUSED AND ON ANY THEORY OF LIABILITY, WHETHER IN CONTRACT, STRICT LIABILITY, OR TORT (INCLUDING NEGLIGENCE OR OTHERWISE) ARISING IN ANY WAY OUT OF THE USE OF THIS SOFTWARE, EVEN IF ADVISED OF THE POSSIBILITY OF SUCH DAMAGE.

## 2. Authors Name List

All product names mentioned herein are trademarks of their respective owners. The following notices are required to satisfy the license terms of the software that we have mentioned in this document:

- This product includes software developed by the University of California, Berkeley and its contributors.
- This product includes software developed by Jonathan R. Stone for the NetBSD Project.
- This product includes software developed by the NetBSD Foundation, Inc. and its contributors.
- This product includes software developed by Manuel Bouyer.
- This product includes software developed by Charles Hannum.
- This product includes software developed by Charles M. Hannum.
- This product includes software developed by Christopher G. Demetriou.
- This product includes software developed by ToolS GmbH.
- This product includes software developed by Terrence R. Lambert.
- This product includes software developed by Adam Glass and Charles Hannum.
- This product includes software developed by Theo de Raadt.
- This product includes software developed by Jonathan Stone and Jason R. Thorpe for the NetBSD Project.
- This product includes software developed by the University of California, Lawrence Berkeley Laboratory and its contributors.
- This product includes software developed by Christos Zoulas.
- This product includes software developed by Christopher G. Demetriou for the NetBSD Project.
- This product includes software developed by Paul Kranenburg.
- This product includes software developed by Adam Glass.
- This product includes software developed by Jonathan Stone.
- This product includes software developed by Jonathan Stone for the NetBSD Project.
- This product includes software developed by Winning Strategies, Inc.
- This product includes software developed by Frank van der Linden for the NetBSD Project.
- This product includes software developed for the NetBSD Project by Frank van der Linden.
- This product includes software developed for the NetBSD Project by Jason R. Thorpe.
- The software was developed by the University of California, Berkeley.
- This product includes software developed by Chris Provenzano, the University of California, Berkeley, and contributors.

---

## Sablotron

---

Sablotron (Version 0.82) Copyright (c) 2000 Ginger Alliance Ltd. All Rights Reserve

- a) The application software installed on this product includes the Sablotron software Version 0.82 (hereinafter, "Sablotron 0.82"), with modifications made by the product manufacturer. The original code of the Sablotron 0.82 is provided by Ginger Alliance Ltd., the initial developer, and the modified code of the Sablotron 0.82 has been derived from such original code provided by Ginger Alliance Ltd.
- b) The product manufacturer provides warranty and support to the application software of this product including the Sablotron 0.82 as modified, and the product manufacturer makes Ginger Alliance Ltd., the initial developer of the Sablotron 0.82, free from these obligations.
- c) The Sablotron 0.82 and the modifications thereof are made available under the terms of Mozilla Public License Version 1.1 (hereinafter, "MPL 1.1"), and the application software of this product constitutes the "Larger Work" as defined in MPL 1.1. The application software of this product except for the Sablotron 0.82 as modified is licensed by the product manufacturer under separate agreement(s).
- d) The source code of the modified code of the Sablotron 0.82 is available at: <http://support-download.com/services/device/sablot/notice082.html>.
- e) The source code of the Sablotron software is available at: <http://www.ginger-all.com>.
- f) MPL 1.1 is available at: <http://www.mozilla.org/MPL/MPL-1.1.html>.

---

## JPEG LIBRARY

---

- The software installed on this product is based in part on the work of the Independent JPEG Group.



---

## SASL

---

CMU libsasl

Tim Martin

Rob Earhart

Rob Siemborski

Copyright (c) 2001 Carnegie Mellon University. All rights reserved.

Redistribution and use in source and binary forms, with or without modification, are permitted provided that the following conditions are met:

- ① Redistributions of source code must retain the above copyright notice, this list of conditions and the following disclaimer.
- ② Redistributions in binary form must reproduce the above copyright notice, this list of conditions and the following disclaimer in the documentation and/or other materials provided with the distribution.
- ③ The name "Carnegie Mellon University" must not be used to endorse or promote products derived from this software without prior written permission. For permission or any other legal details, please contact:  
Office of Technology Transfer  
Carnegie Mellon University  
5000 Forbes Avenue  
Pittsburgh, PA 15213-3890  
(412) 268-4387, fax: (412) 268-7395  
tech-transfer@andrew.cmu.edu
- ④ Redistributions of any form whatsoever must retain the following acknowledgment:  
"This product includes software developed by Computing Services at Carnegie Mellon University (<http://www.cmu.edu/computing/>)."

CARNEGIE MELLON UNIVERSITY DISCLAIMS ALL WARRANTIES WITH REGARD TO THIS SOFTWARE, INCLUDING ALL IMPLIED WARRANTIES OF MERCHANTABILITY AND FITNESS, IN NO EVENT SHALL CARNEGIE MELLON UNIVERSITY BE LIABLE FOR ANY SPECIAL, INDIRECT OR CONSEQUENTIAL DAMAGES OR ANY DAMAGES WHATSOEVER RESULTING FROM LOSS OF USE, DATA OR PROFITS, WHETHER IN AN ACTION OF CONTRACT, NEGLIGENCE OR OTHER TORTIOUS ACTION, ARISING OUT OF OR IN CONNECTION WITH THE USE OR PERFORMANCE OF THIS SOFTWARE.

---

**MD4**

---

Copyright (C) 1990-2, RSA Data Security, Inc. All rights reserved.

License to copy and use this software is granted provided that it is identified as the "RSA Data Security, Inc. MD4 Message-Digest Algorithm" in all material mentioning or referencing this software or this function.

License is also granted to make and use derivative works provided that such works are identified as "derived from the RSA Data Security, Inc. MD4 Message-Digest Algorithm" in all material mentioning or referencing the derived work.

RSA Data Security, Inc. makes no representations concerning either the merchantability of this software or the suitability of this software for any particular purpose. It is provided "as is" without express or implied warranty of any kind.

These notices must be retained in any copies of any part of this documentation and/or software.

---

**MD5**

---

Copyright (C) 1991-2, RSA Data Security, Inc. Created 1991. All rights reserved.

License to copy and use this software is granted provided that it is identified as the "RSA Data Security, Inc. MD5 Message-Digest Algorithm" in all material mentioning or referencing this software or this function.

License is also granted to make and use derivative works provided that such works are identified as "derived from the RSA Data Security, Inc. MD5 Message-Digest Algorithm" in all material mentioning or referencing the derived work.

RSA Data Security, Inc. makes no representations concerning either the merchantability of this software or the suitability of this software for any particular purpose. It is provided "as is" without express or implied warranty of any kind.

These notices must be retained in any copies of any part of this documentation and/or software.

# How to Read This Manual

---

## Symbols

---

The following set of symbols is used in this manual.

### **WARNING:**

This symbol indicates a potentially hazardous situation that might result in death or serious injury when you misuse the machine without following the instructions under this symbol. Be sure to read the instructions, all of which are described in the Safety Information section.

### **CAUTION:**

This symbol indicates a potentially hazardous situation that might result in minor or moderate injury or property damage that does not involve personal injury when you misuse the machine without following the instructions under this symbol. Be sure to read the instructions, all of which are described in the Safety Information section.

\* The statements above are notes for your safety.

### **Important**

If this instruction is not followed, paper might be misfed, originals might be damaged, or data might be lost. Be sure to read this.

### **Preparation**

This symbol indicates information or preparations required prior to operating.

### **Note**

This symbol indicates precautions for operation, or actions to take after abnormal operation.

### **Limitation**

This symbol indicates numerical limits, functions that cannot be used together, or conditions in which a particular function cannot be used.

### **Reference**

This symbol indicates a reference.

[    ]

Keys that appear on the machine's display panel.

[    ]

Keys built into the machine's control panel.

# Safety Information

When using this machine, the following safety precautions should always be followed.

---

## Safety During Operation

---

In this manual, the following important symbols are used:

**⚠ WARNING:**  
*Indicates a potentially hazardous situation which, if instructions are not followed, could result in death or serious injury.*

**⚠ CAUTION:**  
*Indicates a potentially hazardous situation which, if instructions are not followed, may result in minor or moderate injury or damage to property.*

---

### **⚠ WARNING:**

---

- ***Do not damage, break or make any modifications to the power cord. Do not place heavy objects on it. Do not pull it hard nor bend it more than necessary. These actions could cause an electric shock or fire.***
- ***Disconnect the power plug (by pulling the plug, not the cable) if the power cable or plug becomes frayed or otherwise damaged.***
- ***To avoid hazardous electric shock, do not remove any covers or screws other than those specified in this manual.***
- ***Turn off the power and disconnect the power plug (by pulling the plug, not the cable) if any of the following occurs:***
  - ***You spill something into the machine.***
  - ***You suspect that your machine needs service or repair.***
  - ***The external housing of your machine has been damaged.***
- ***Keep the machine away from flammable liquids, gases, and aerosols. A fire or an electric shock might occur.***
- ***Connect the power cord directly into a wall outlet and never use an extension cord.***
- ***Only connect the machine to the power source described in this manual.***
- ***Disposal can take place at our authorized dealer or at appropriate collection sites.***

---

**⚠ CAUTION:**

---

- *After you move the machine, use the caster fixture to fix it in place. Otherwise the machine might move or come down to cause an injury.*
- *If you use the machine in a confined space, make sure there is a continuous air turnover.*
- *Keep the machine away from humidity and dust. Otherwise a fire or an electric shock might occur.*
- *Protect the machine from dampness or wet weather, such as rain and snow.*
- *Do not place the machine on an unstable or tilted surface. If it topples over, an injury might occur.*
- *Unplug the power cord from the wall outlet before you move the machine. While moving the machine, you should take care that the power cord will not be damaged under the machine.*
- *When you disconnect the power plug from the wall outlet, always pull the plug (not the cable).*
- *Do not allow paper clips, staples, or other small metallic objects to fall inside the machine.*
- *For environmental reasons, do not dispose of the machine or expended supply waste at household waste collection points. Disposal can take place at an authorized dealer.*
- *When disposing of a used ink container, reattach the cap to prevent ink from splattering.*
- *Be careful not to get ink on your clothes when replacing an ink container. Ink stains on clothes are hard to remove.*
- *Be careful not to cut yourself on any sharp edges when you reach inside the machine to remove misfed sheets of paper or masters.*
- *If ink comes into contact with your eyes, rinse immediately in running water. For other symptoms, consult a doctor.*
- *Keep the ink or ink container out of reach of children.*
- *If ink is ingested, induce vomiting by drinking a strong saline solution. Consult a doctor immediately.*
- *If your skin comes into contact with ink, wash the affected area thoroughly with soap and water.*
- *While printing, do not touch the belt at the end of the paper delivery tray or the job separator. Otherwise, an injury might occur.*
- *Our products are engineered to meet the high standards of quality and functionality, and we recommend that you only use the expendable supplies available at an authorized dealer.*

# Positions of ⚠ WARNING and ⚠ CAUTION Labels

This machine has labels for ⚠WARNING and ⚠CAUTION at the positions shown below. For safety, please follow the instructions and handle the machine as indicated.

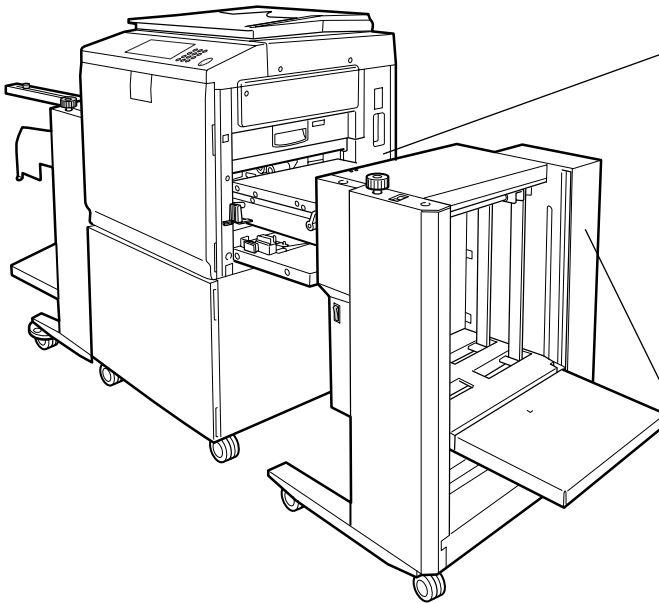

**WARNING / ATTENTION**  
**ACHTUNG**  
**ATTENZIONE**  
**AVISO**



- To avoid injury, do not touch moving parts or insert your fingers in the opening during machine operation. To de-energize moving parts, open the front cover.
- Afin d'éviter des blessures, ne pas toucher de pièces en mouvement ou insérer vos doigts dans l'ouverture en cours d'utilisation.
- Pour arrêter le fonctionnement du magasin, ouvrir le carter frontal.
- Verletzungsgefahr! Bei Betrieb nicht in die Öffnung greifen. Um bewegliche Teile stromlos zu schalten, Frontklappe öffnen.
- Per evitare incidenti, non toccare le parti in movimento o mettere le dita nell'apertura mentre la macchina è in funzione. Per togliere l'energia elettrica alle parti in movimento, aprire il coperchio frontale del cassetto.
- Para evitar dañarse, no toque las partes móviles ni ponga sus dedos en la abertura, mientras la máquina esté en funcionamiento. Para desactivar las partes móviles, abra la cubierta frontal.

>PS<

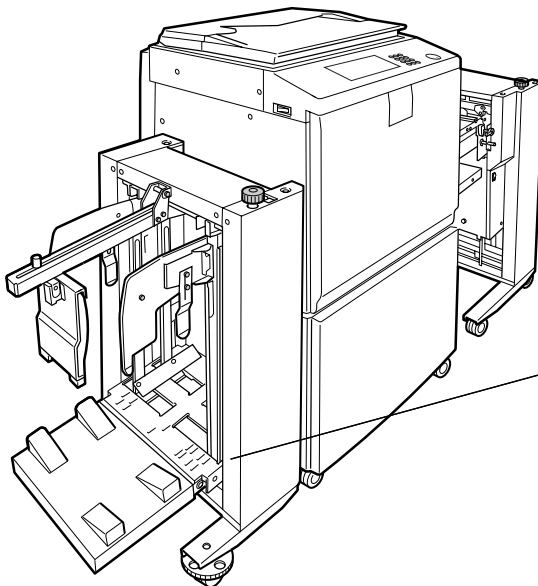

**WARNING**  
**AVERTISSEMENT**  
**VORSICHT**  
**AVVERTIMENTO**  
**ADVERTENCIA 警告**



- Do not place anything under the trays including hands and feet.
- Ne rien placer sous les magasins (attention aux mains et aux pieds).
- Nicht mit Händen oder Füßen unter das Papierfach und keine Gegenstände darunterlegen.
- Non posizionare niente sotto i cassette, incluso mani e piedi.
- No coloque nada debajo de las bandejas, manos y pies incluidos.
- 可動部の下に手足や物を入れないでください。

>PS<

AJK100S

# Guide To Components

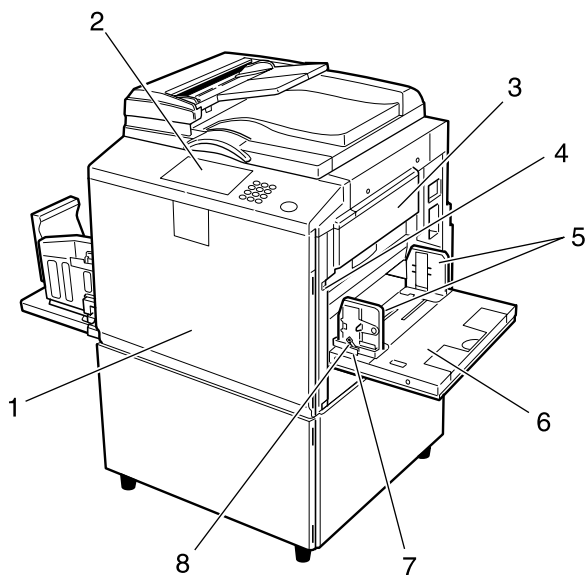

AJK111S

## **1. Front door**

Open to access the inside of the machine.

## **2. Control panel**

See p.17 "Control Panel".

## **3. Master making unit**

Open this unit when installing the master.

## **4. Paper feed tray down key**

Press to lower the paper feed tray.

## **5. Paper feed side plates**

Prevent paper skewing.

## **6. Paper feed tray**

Load paper here.

## **7. Paper feed side plates knob**

Use to move the side plates.

## **8. Paper feed side plates knob lock lever**

Locks the paper feed side plates.

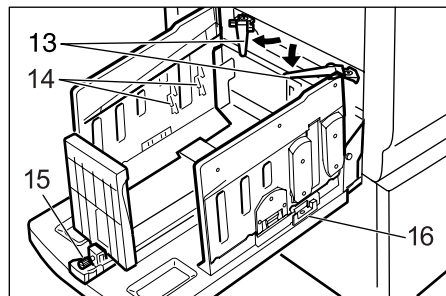
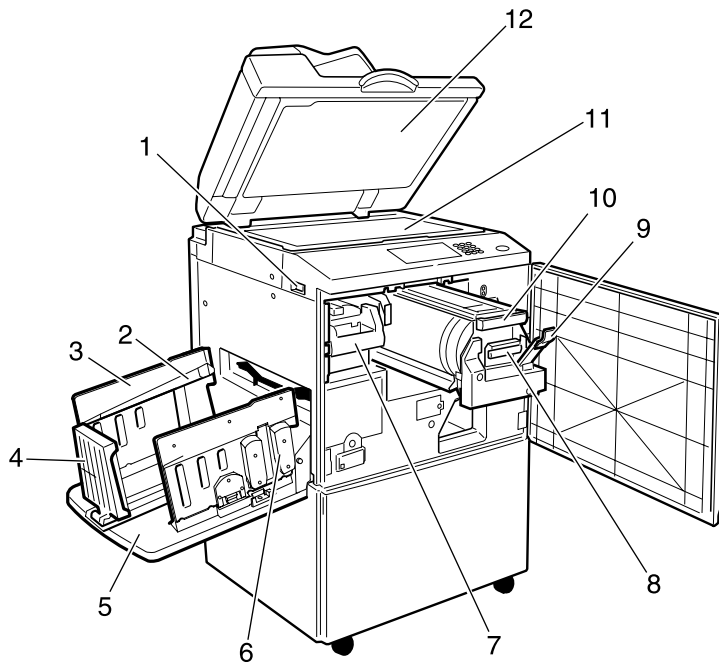

AJK110S

**1. Main switch**

Use to turn the power on or off.

**2. Paper alignment wings**

Lift or lower the wings depending on the type of paper being used.

**3. Paper delivery side plates**

Use to align the prints on the paper delivery tray.

**4. Paper delivery end plate**

This plate aligns the leading edge of prints.

**5. Paper delivery tray**

Completed prints are delivered here.

**6. Chocks**

Use to adjust the buffer fins.

**7. Master eject unit handle E1**

Use to pull out the master eject unit.

**8. Ink holder**

Set the ink cartridge in this holder.

**9. Drum unit lock lever B1**

Lower to unlock and pull out the drum unit.

**10. Drum unit**

The master is wrapped around this unit.

**11. Exposure glass**

Position originals here face down for printing.





**12. Exposure glass cover (optional) or Auto Document Feeder (optional)**

Lower this cover over an original on the exposure glass. If you have the ADF, load a stack of originals here. They will be fed automatically, one by one.

(The illustration shows the ADF.)

**13. Trailing edge guides**

Swing out these guides when you use A4, 8<sup>1</sup>/<sub>2</sub>" × 11"   paper.

**14. Buffer fins**

Use to stack prints neatly.

**15. Paper delivery end plate knob**

Use to move the end plate.

**16. Paper delivery side plate knobs**

Use to move the side plates.

# Options

## Option List

Options	Model Name
Auto Document Feeder (ADF)	DF Type 85
Exposure Glass Cover	Platen Cover Type 1018
Large Capacity System (LCS)	LS3000R
Drum unit	Metric version: Drum Type 90 <A3> / <A4> Inch version: Drum Type 90 <A4> (8 <sup>1</sup> / <sub>2</sub> " × 11") / <11" × 17">
Twin colour press roller printing system	TC-IIR
PostScript board	PostScript3 Board Type 2
IEEE 1284 parallel board	IEEE 1284 Parallel Board Type 1
IEEE 802.11b interface board	IEEE 802.11b I/F Unit Type 1
Memory unit	Memory Unit TypeC (128 MB/256 MB)
HDD board	Extension HDD Type 1
Key Counter	–

---

## Guide to Major Options

---

### ❖ Auto Document Feeder (ADF)

Load a stack of originals here. They will be fed automatically, one by one.

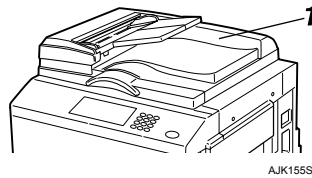

### 1. Auto Document Feeder

### ❖ Large Capacity System (LCS): Large capacity input tray (LCIT)

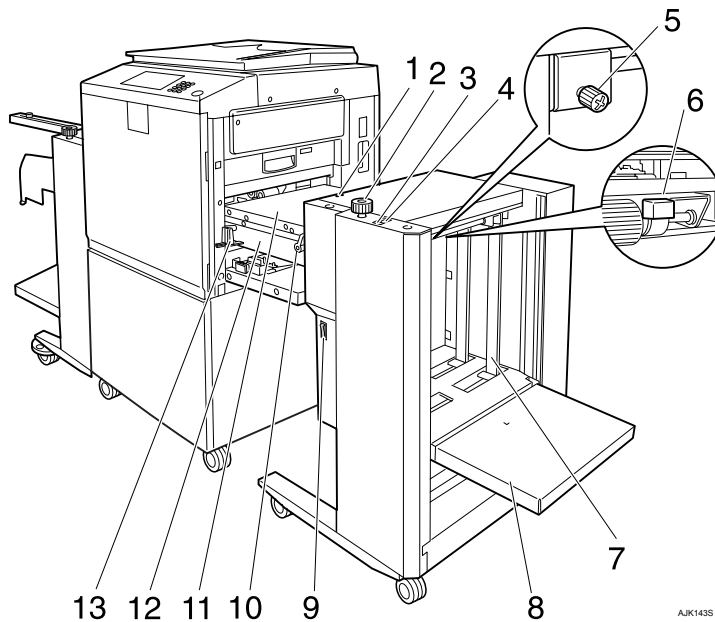

**1. Indicators**

**2. Side guide adjustment knob**

**3. Down button**

**4. Up button**

**5. Side guide screw**

**6. Feeding pressure lever**

**7. Side guides**

**8. Input tray**

**9. Power switch**

**10. Cover release lever**

**11. Cover**

**12. Intermediate feeding section**

**13. LCIT release lever**

❖ **Large Capacity System (LCS): Large capacity output tray (LCOT)**

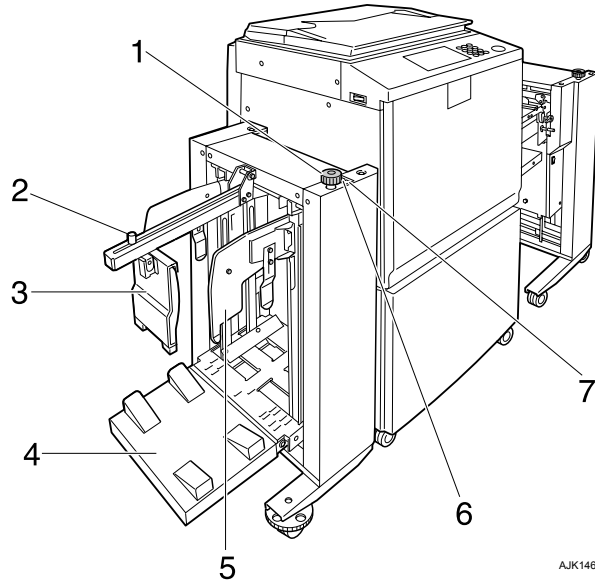

- 1. Side guide adjustment knob**
- 2. End plate screw**
- 3. End plate**
- 4. Output tray**

- 5. Side guides**
- 6. Up button**
- 7. Down button**

# Control Panel

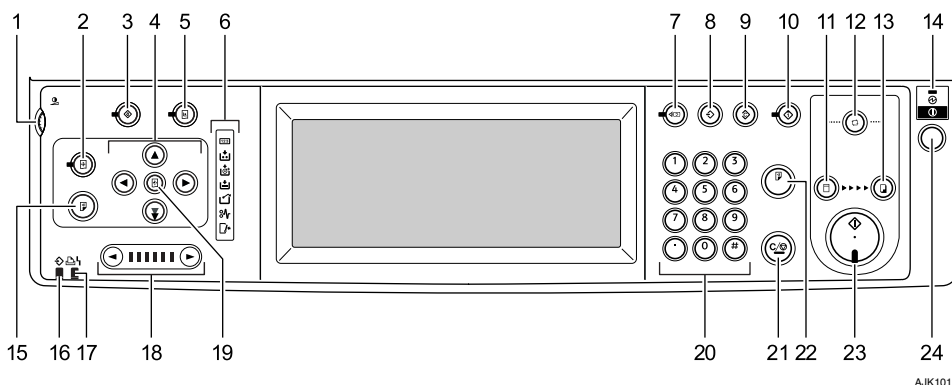

AJK101S

## 1. Screen contrast knob

Adjusts the brightness of the display panel.

## 2. [Image Position] key

Adjusts the position of printed images.

## 3. [User Tools] key

Press to change the default settings to meet your requirements.



## 4. Position Setting keys

Adjusts the position of printed images.



## 5. [Printer Settings] key



Press to change the default settings for online printing.



## 6. Indicators



: Open Cover/Unit indicator. See p.143 “When the Open Cover/Unit Indicator Lights”.



Let you know the status of the machine.

: Add Ink indicator. See p.126 “Adding Ink”.

: Master End indicator. See p.128 “Replacing the Master Roll”.

: Load Paper indicator. See p.124 “Loading Paper”.

: Master Eject indicator. See p.144 “Removing the Used Master”.

: Misfeed indicator. See p.130 “Clearing Misfeeds”.

## 7. [Check Modes] key

Press this key to check settings.

## 8. [Program] key

Press to register frequently used settings, or to recall registered settings.

## 9. [Clear Modes] key

Press to clear previously entered print job settings.

## 10. [Hold Data-in] key

Press to reject the online print temporarily.

## 11. [Master Making] mode select key

Press to select the master making mode.

## 12. [Auto Cycle] key

Press to make masters and prints in a single operation. See p.44 “Basic Procedure”.

## 13. [Print] mode select key

Press to select the print mode.

## 14. Main power indicator

The main power indicator lights up when the main switch is turned on.

## 15. [Proof] key

Press to make a proof print.

## Note

 Same as 22.

## **16. Data In indicator (Green)**

- On: Data waiting for Master Making and printing is in the machine.
- Blinking: Data is being received, or Master Making or printing is in progress.
- Off: Master Making and printing are completed.

## **17. Error indicator (Red)**

- On: An error has occurred. Master Making and printing stops.
- Off: Normal status

## **18. Speed setting keys**

Press to adjust the printing speed. See p.55 "Changing the Printing Speed".

## **19. [Initial position] key**

Press to reset to the default image position.

## **20. Number keys**

Press to enter the desired number of prints and data for selected modes.

## **21. [Clear/Stop] key**

- Clear  
Press to delete a number entered.
- Stop  
Press to stop a job in progress.

## **22. [Proof] key**

Press to make a proof print.

### **Note**

- Same as 15.

## **23. [Start] key**

Press to start making masters or printing.

## **24. Operation switch**

Press this switch to operate the machine in Energy Saver mode.

To go back into the Energy Saver mode, press this switch.

# Display Panel

The display panel shows machine status, error messages and function menus.

The function items displayed serve as selector keys. You can select or specify an item by lightly pressing them.

When you select or specify an item on the display panel, it is highlighted like **Full Size**. Keys appearing as **OK** cannot be used.

## Important

- ❑ A force or impact of more than 30 N (about 3 kgf) will damage the display panel.

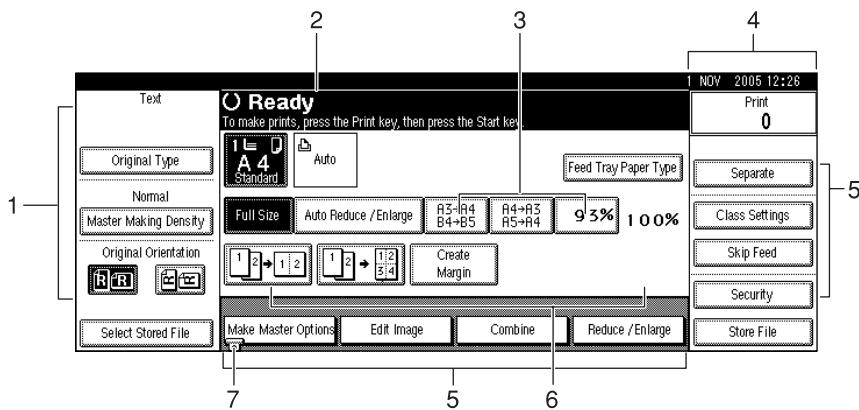

AJK170S

**1. Original functions.**

**2. Operational status and messages.**

**3. You can register up to three frequently used reduce/enlarge ratios other than the fixed reduce/enlarge ratios.**

**4. Numbers of prints set.**

**5. Displays available functions. Press a function name to display its menu. For example, press [Reduce / Enlarge] to bring up the Reduce/Enlarge menu.**

**6. Displays contents of the Shortcut keys. You can register frequently used functions in these keys.**

**7. A clip mark indicates the currently selected function.**

---

## Common Key Operations

---

The following keys are common to all screens.

### ❖ Key list

[OK]	Acknowledges a selected function or entered values, and then returns to the previous display
[Cancel]	Deletes a selected function or entered values, and then returns to the previous display
[▲Prev.], [▼Next]	Moves to the previous page or the next page when all functions cannot be displayed on one page.
[OK] [Yes]	Closes displayed messages.
[Clear]	Clears entered values and does not change the settings.
[Exit]	Returns to the previous display.



# Turning On the Power

## ❖ Main switch (left side of the machine)

Press to activate the machine. When the machine has finished warming up, you can make master and prints.

Turning off this switch will completely turn off power to the machine.

## Note

- ❑ This machine automatically enters Energy Saver Mode or turns itself off if you do not use it for a certain period. See p.46 "Saving Energy" and p.46 "Auto Off Timer".

---

## Turning On the Power

---

- 1** Make sure that the power cord is firmly plugged into the wall outlet.

- 2** Open the switch cover and turn on the main switch.

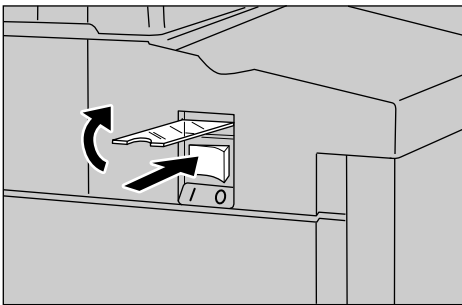

The main power indicator turns on.

## Important

- ❑ Do not turn off the main power immediately after it has been turned on. Otherwise it may result in damage to the hard disk or memory, leading to the malfunctioning of the machine.

---

## Turning Off the Power

---

## Important

- ❑ Be sure to turn off the main switch before pulling out the power plug. Not doing this may result in damage to the hard disk or memory.

- 1** Open the switch cover, and turn off the main switch.

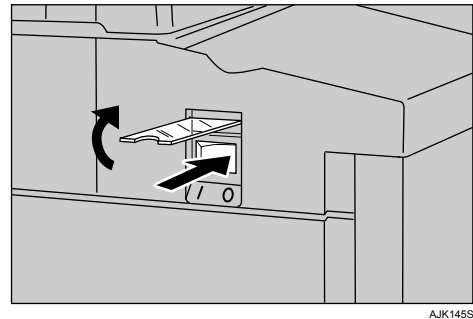

The main power indicator goes off.



# 1. Before Using the Machine















## Originals

---











### Size and Weights of Recommended Originals

---

#### ❖ Metric version

Where original is placed	Original size	Original weight
Exposure glass	A3  , B4  , A4   , B5 JIS (Japanese Industrial Standard)  	--
ADF	A3  , B4 JIS  , A4   , B5 JIS   , A5  	52–128 g/m <sup>2</sup>

#### ❖ Inch version

Where original is placed	Original size	Original weight
Exposure glass	11" × 17"  , 8 <sup>1</sup> / <sub>2</sub> " × 14"  , 8 <sup>1</sup> / <sub>2</sub> " × 11"  	--
ADF	11" × 17"  , 8 <sup>1</sup> / <sub>2</sub> " × 14"  , 8 <sup>1</sup> / <sub>2</sub> " × 11"   , 5 <sup>1</sup> / <sub>2</sub> " × 8 <sup>1</sup> / <sub>2</sub> "  	14–28 lb.

#### Note

- The maximum number of originals that can be placed in the ADF is about 50 (80 g/m<sup>2</sup>, 20 lb).
- If you do not lift the exposure glass cover more than 30° when you place another original, the machine might not detect the next original size correctly.

---

## **Non compatible originals for the Auto Document Feeder(ADF)**

---

1

Placing the following types of originals in the ADF can cause paper misfeeds or result in damage to the originals. Place these originals on the exposure glass instead.

- Originals other than those specified on p.23 “Size and Weights of Recommended Originals”.
- Perforated or torn originals
- Curled, folded, or creased originals
- Pasted originals
- Originals with any kind of coating, such as thermal fax paper, art paper, aluminum foil, carbon paper, or conductive paper.
- Originals with indexes, tags, other projecting parts
- Stapled or clipped original
- Sticky originals such as translucent paper
- Thin originals that have low stiffness
- Thick originals such as postcards
- Bound originals such as books
- Transparent originals such as OHP transparencies or translucent paper

## Sizes difficult to detect









It is difficult for the machine to automatically detect the sizes of the following types of originals, so select the paper size manually.

- Originals with indexes, tags, or other protrusions
- Transparent originals such as OHP transparencies or translucent paper
- Text or picture dense original
- Originals containing solid images
- Originals containing solid images around their edges







## Sizes Detectable by Auto Paper Select

○ : Detectable size × : Undetectable size

### ❖ Metric version

Size	A3 	B4 JIS 	A4  	B5 JIS  	A5  
Location of the original					
Exposure glass	○	○	○	○	×
ADF	○	○	○	○	○

### ❖ Inch version

Size	11" × 17" 	8 <sup>1</sup> / <sub>2</sub> " × 14" 	8 <sup>1</sup> / <sub>2</sub> " × 11"  	5 <sup>1</sup> / <sub>2</sub> " × 8 <sup>1</sup> / <sub>2</sub> "  
Location of the original				
Exposure glass	○	○	○	×
ADF	○	○	○	○

# Print Paper

1

## Recommended Paper Size and Type

The following limitations apply:

	Paper Size		Paper Weight
	Metric	Inch	
Paper feed tray	A3 ☐, B4 JIS ☐, A4 ☐☐, B5 JIS ☐☐, A5 ☐, B6 JIS ☐, A6 ☐ Others (Vertical: 70 - 297 mm, Horizontal: 148 - 432 mm)	11" × 17" ☐, 8½" × 14" ☐, 8½" × 11" ☐☐, 5½" × 8½" ☐☐ Others (Vertical: 2.76" - 11.7", Horizontal: 5.83" - 17")	47.1 - 209.3 g/m <sup>2</sup> , 12.5 - 55.6 lb

## Recommended for the LCIT

The size and quantity of paper that can be loaded on the LCIT are as follows.

Paper size		Paper weight	Tray capacity
Metric version	Inch version		
Maximum: 297 × 432 mm (325 × 447 mm <sup>*1</sup> ) Minimum: 128 × 182 mm	Maximum: 11.6" × 17.0" (12.7" × 17.5" <sup>*1</sup> ) Minimum: 5.1" × 7.1"	47.1 – 209.3 g/m <sup>2</sup> (12.5 – 55.61 lb.)	3000 sheets (80 g/m <sup>2</sup> , 20 lb.) Paper stack height: Less than 320 mm (12.5")

<sup>\*1</sup> When the image position is set to 0 mm (0")

 **Note**

- ☐ Tray capacity is based on using high quality 80 g/m<sup>2</sup> (20 lb.) paper. The number of sheets shown is approximate.

## Recommended for the LCOT

Paper size		Paper weight	Tray capacity
Metric version	Inch version		
Maximum: 297 × 432 mm (325 × 447 mm <sup>*1</sup> ) Minimum: 70 × 148 mm (When the LCIT is installed: 128 × 182 mm)	Maximum: 11.6" × 17.0" (12.7" × 17.5" <sup>*1</sup> ) Minimum: 2.8" × 5.9" (When the LCIT is installed: 5.1" × 7.1")	47.1 – 209.3 g/m <sup>2</sup> (12.5 – 55.61 lb.)	3000 sheets (80 g/m <sup>2</sup> , 20 lb.) Paper stack height: Less than 345 mm (13.5")

<sup>\*1</sup> When the image position is set to 0 mm (0")

### Note

- Tray capacity is based on using high quality 80 g/m<sup>2</sup> (20 lb.) paper. The number of sheets shown is approximate.

## Non-recommended Paper

The following types of paper are not recommended for this machine:

- Roughly cut paper
- Paper of different thickness in the same stack
- Envelopes heavier than 85 g/m<sup>2</sup>, 22 lb.
- Folded, curled, creased, or damaged paper
- Damp paper
- Torn paper
- Slippery paper
- Rough paper
- Paper with any kind of coating (such as carbon)
- Short grain paper
- Thin paper that has low stiffness
- Paper that is prone to generate a lot of paper dust
- Grained paper loaded with the direction of the grain perpendicular to the feed direction
- Certain types of long thin envelopes.  
E.g. international mail envelopes

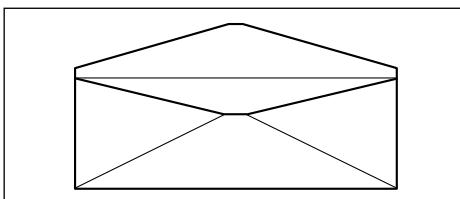

ZFX040E

- The following types of envelopes

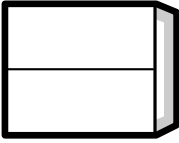
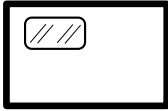
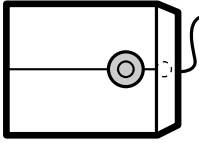
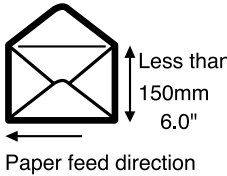
Envelopes with glue or gum	Envelopes with windows	Envelopes with round tags	Open envelopes
			

**Note**

- Do not use inkjet paper. It does not absorb ink well, print will smudge if rubbed, and the back of paper may be dirtied.
- If you print on rough grained paper, the print image might be blurred.
- You can use A3 (297 × 420 mm) or 11" × 17" originals or printing paper. When you want to print the entire image of an A3, 11" × 17" original, select Reduce mode because the maximum print areas are as follows:
  - Metric version: 290 × 412 mm, 11.4" × 16.2"
  - Inch version: 290 × 422 mm, 11.4" × 16.6"
- When you use A3, 11" × 17" and 209.3 g/m<sup>2</sup>, 55.6 lb paper, slow the printing speed down to setting 1, 2, or 3.

**Important**

- Correct curls in the paper before placing it in the machine. When you cannot correct the paper curl, stack the paper with the curl face down or face up as shown in the illustration. If the paper is curled, it might wrap around the drum or stains might appear.

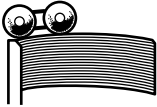
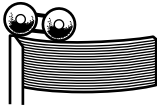
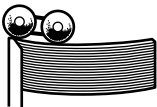
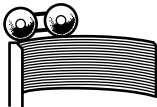
	Right	Wrong
Thin Paper		
Thick Paper		

TPEY990E



---

## Storing Paper

---

 **Note**

- When storing paper, the following precautions should always be taken:
  - Do not store paper where it will be exposed to direct sunlight.
  - Avoid storing paper in humid (greater than 70%) areas.
  - Store on a flat surface.
- Keep open reams of paper in the package and store as you would unopened paper.

# Printing Size

1

## Maximum print size

- Metric version:  
290 × 412 mm, 11.4" × 16.2"(approx. A3 size)
- Inch version:  
290 × 422 mm, 11.4" × 16.6"

At low temperatures, the maximum print size may be somewhat smaller.

## Range that cannot be printed

The first 6 mm, 0.24", of the leading edge and the last 2 mm, 0.08", of the trailing edge cannot be printed. Make sure the leading edge margin is at least 6 mm, 0.24", and the trailing edge margin is at least 2 mm, 0.08".

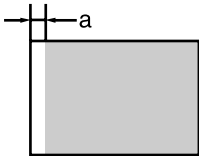
Original	Print
	

a = 6 mm, 0.24"

## Printing Preparations

### Using the Paper Feed Tray and Delivery Tray

#### Loading Paper

- 1 Carefully open the paper feed tray.

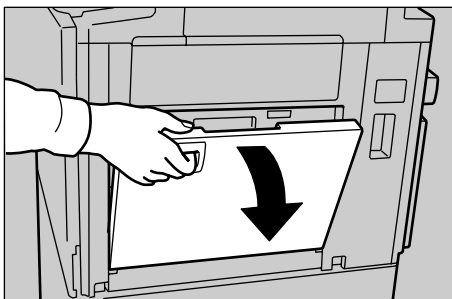

ZDCY130E

- 2 Lift the paper feed side plates.

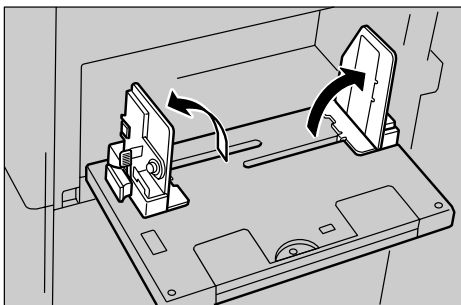

ZDCH050E

#### Note

- When loading larger paper, slide out the extender.

- 3 Make sure that the paper feed side plates knob lock lever is raised (lock is released), and then grasp the paper feed side plates knob and adjust the paper feed side plates to match the paper size.

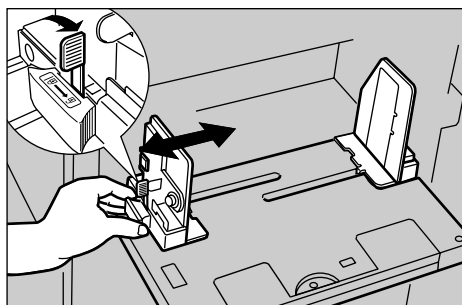

ACY007S

#### Important

- Always adjust the position with the lock lever for the paper feed side plates in the raised position (lock released).

- 4 Place the paper on the paper feed tray.

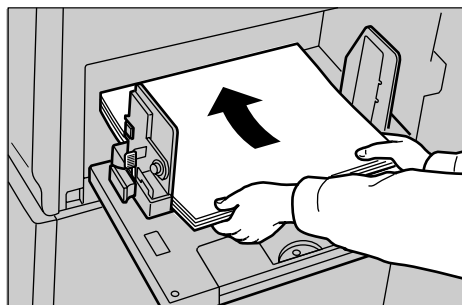

ACY008S

#### Note

- Correct the paper curl before loading the paper. If you cannot do so, stack the paper with the curl face down.

- 5** Make sure that the paper feed side plates are touching both sides of the paper, and then push the lock lever for the side plates down to lock the side plates into position.

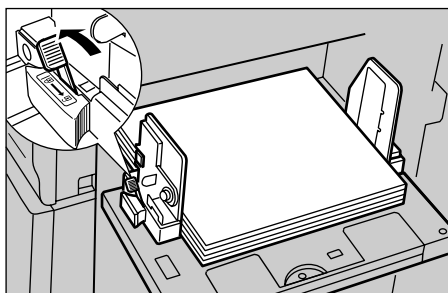

ZDCY041E

### Important

- Always make sure that you push the lock lever for the side plates down to lock the side plates into position.

### Note

- Make sure that the paper size and orientation in the display panel correspond with the actual paper size and orientation set on the paper feed tray.

## Setting Up The Paper Delivery Tray

- 1** Raise the paper delivery tray slightly, and then gently lower it with your hand.

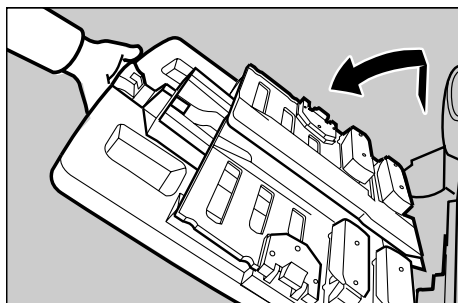

ABL022S

- 2** Lift the paper delivery side plates and adjust them to match the paper size.

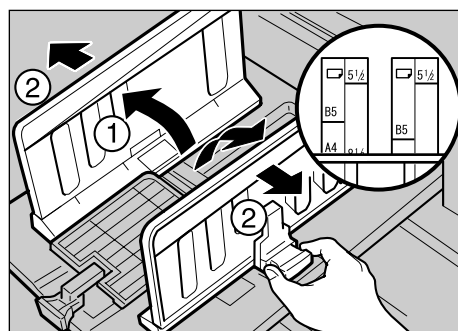

ABL024S

- 3** Lift the paper delivery end plate and adjust it to match the paper size.

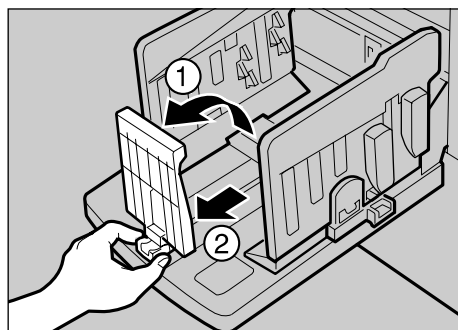

ACY064S



### Note

- The inside of the plates should correspond to the paper size.

## Adjusting the Paper Alignment Wings and Chocks

Use the paper alignment wings and chocks to stack printed paper neatly.

### Note

- ❑ Prints may be delivered curled up if they contain large areas of solid image. If this happens, raise the paper alignment wings to about 45 degrees. When printing on B5 JIS  or A4  of 52.3 g/m<sup>2</sup>, 13.9 lb or thinner, slide the chocks up together.
- ❑ Depending on the type of paper you are using, you may not be able to load to capacity (1000 sheets) when the wings are raised.
- ❑ When printing on 52.3 g/m<sup>2</sup>, 13.9 lb or thinner at a fast speed, paper jams (C) may occur in the paper exit area. If this happens, do the following:
  - Decrease print speed.

### Reference

p.55 "Changing the Printing Speed"

- Lower the paper alignment wings.
- Push the end plate toward the paper delivery tray edge.
- ❑ When the paper alignment wings are raised, prints may not be delivered neatly stacked, depending on paper type. If this happens, lower the wings.

### ❖ Paper alignment wings

Adjust the paper alignment wings.

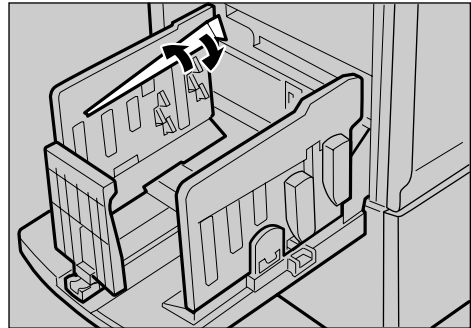

ACY053S

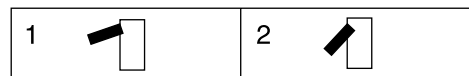

1. Raise the wings fully.
2. Raise the wings to about 45 degrees.





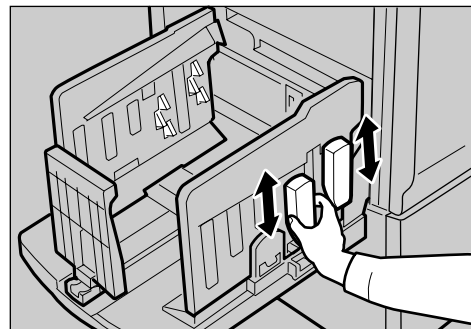













### ❖ Chocks

Slide the chocks up or down to adjust the buffer fins to match the paper size and thickness.







ACY054S

Adjust the paper alignment wings and chocks according to paper size and thickness, as follows:

Paper Weight	Paper Size	Paper alignment wings	Chocks
128 g/m <sup>2</sup> , 34 lb or thicker	A3  , 11" × 17"  , B4 JIS 	Lower the wings.	Down
	A4  , B5 JIS  	Lower the wings.	Down
52.3 g/m <sup>2</sup> – 128 g/m <sup>2</sup> , 13.9 lb to 34 lb	A3  , 11" × 17"  , B4 JIS 	Raise the wings fully.	Up
	A4  , B5 JIS  	Raise the wings to about 45 degrees.	Up
52.3g/m <sup>2</sup> , 13.9 lb or thinner	A3  , 11" × 17"  , B4 JIS 	Raise the wings to about 45 degrees.	Down
	A4  , B5 JIS  	Raise the wings to about 45 degrees.	Down

### Using the trailing edge guides

When printing on A4 , , 8<sup>1</sup>/<sub>2</sub>" ,  
B5 JIS ,  size paper, swing out the  
guides as shown below:

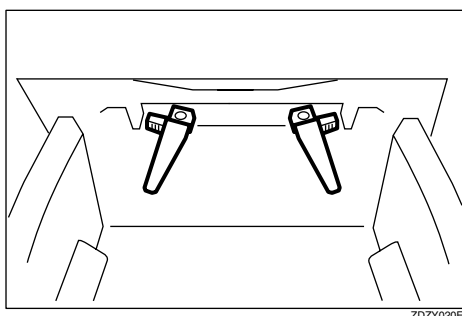

## Using the LCIT and LCOT

### Installing the LCIT

- 1 Open the paper feed tray of the machine.

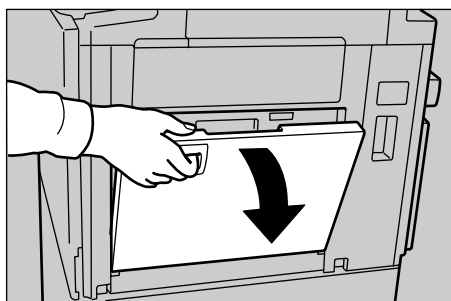

- 2 Make sure that the paper feed side plates knob lock lever is raised (lock is released), and then grasp the paper feed side plates knob and move the side guides of the paper feed tray of the machine to the widest position.

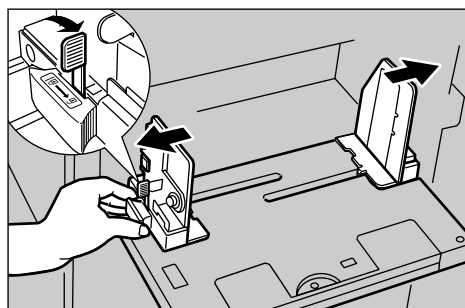

- 3 Lower the paper feed side plates.

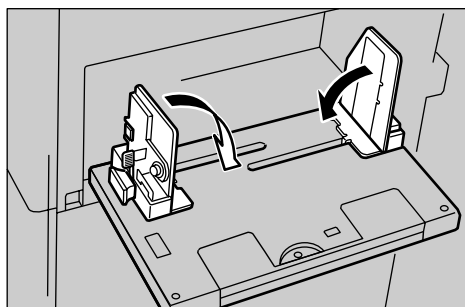

- 4** Hold the handle and unfold the intermediate feeding section of the LCIT.

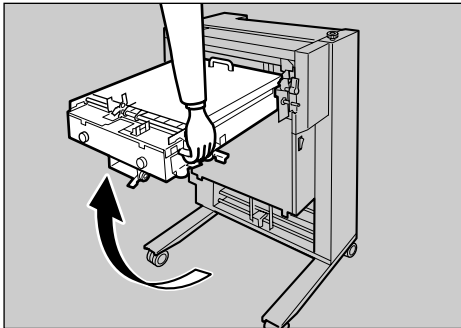

ABQ004S

**Note**

- Do not release the handle.

- 5** Lift the end of the intermediate feeding section and put it down placing the wheeled support bar onto the paper feed tray.

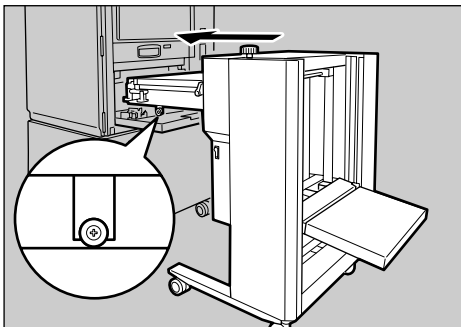

AJK157S

- 6** Push the LCIT into the machine until it clicks.

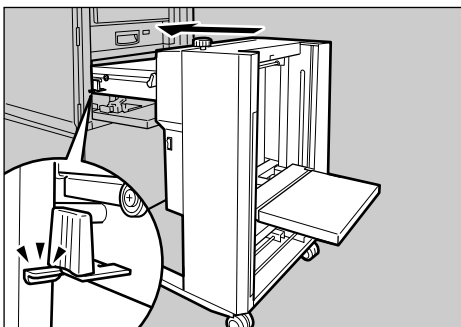

ABQ006S

- 7** Plug the LCIT optical cable into the slot located at the left side of the back of the machine.

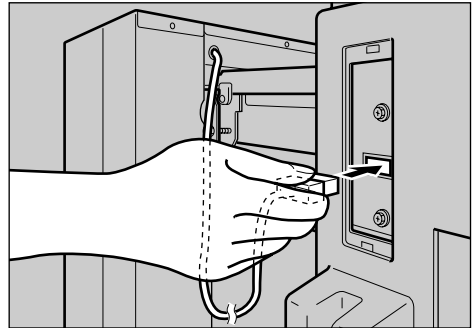

ACY066S

**Turning On the Power**

**Important**

- Make sure to turn on the power switch of the LCS first, and then turn on the main switch of the machine.

- 1** Make sure that the power cord is firmly plugged into the wall outlet.

- 2** Turn the power switch on.  
The green indicator blinks.

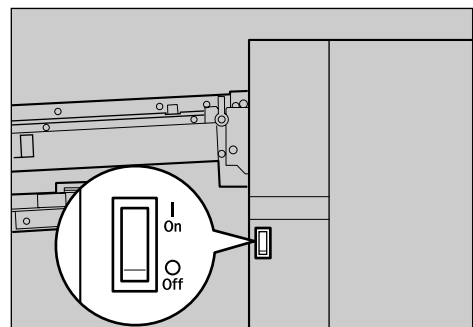

ABQ011S

## Loading Paper

- 1 Turn the side guide adjustment knob to adjust the side guides to the paper size.

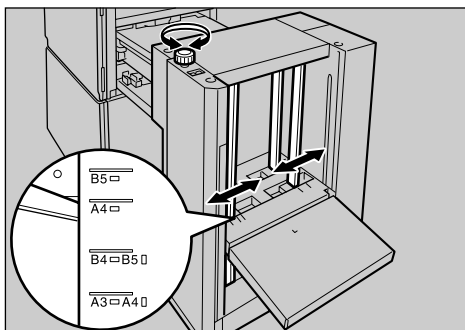

AJK158S

- 2 Tighten the screw to lock the side guides.

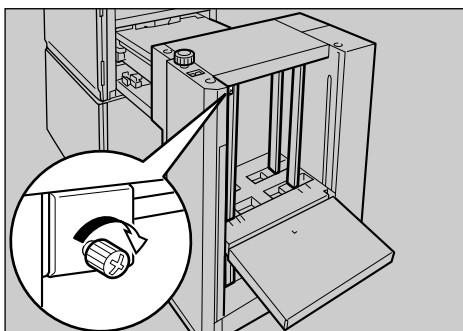

AJK166S

- 3 Load paper.

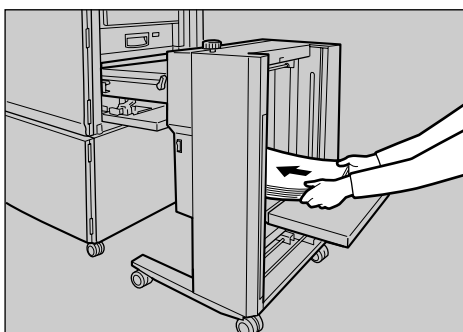

ABQ016S

### Note

- The leading edge of the paper must touch the inside of the LCIT.

## Loading Paper Smaller than B6 JIS (128 × 182 mm, 5.0" × 7.1" )

Paper smaller than B6 JIS must be loaded directly onto the paper feed tray of the machine. The LCIT must be detached.

- 1 Detach the LCIT.
- 2 Load paper onto the paper feed tray.

## Setting up the LCOT

- 1 Press the up button to lift the output tray.

The output tray goes up.

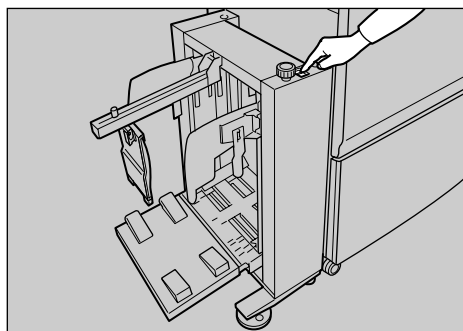

AJK160S

- 2 Turn the side guide adjustment knob to adjust the side guides to the paper size.

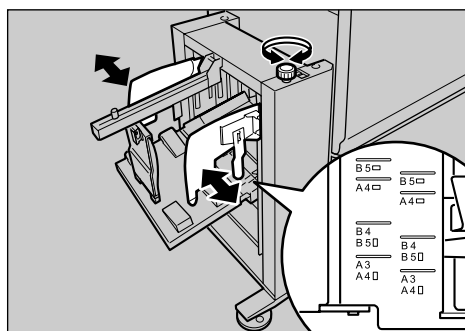

AJK161S

### Note

- Align the inside of the side guides with the appropriate mark on the output tray.



- 3** Loosen the screw for the end plate, adjust it to the paper size, and then tighten the screw to lock the end plate.

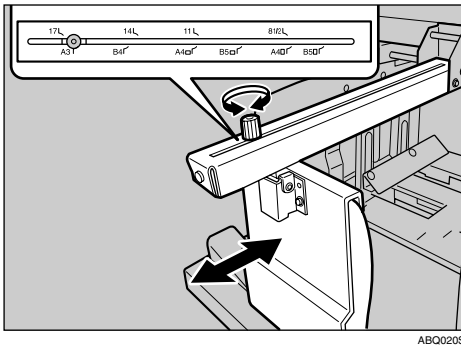

ABQ020S

**Note**

- Align the screw with the appropriate paper size mark.

**Printing on Paper Smaller than B6 JIS**

- 1** Move the side guides outward.

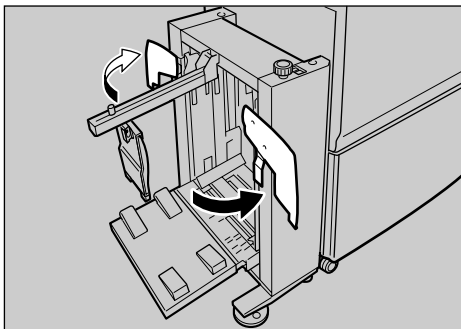

AJK162S

- 2** Loosen the screw for the end plate, move it as close to the machine as possible, and then tighten the screw to lock the end plate.

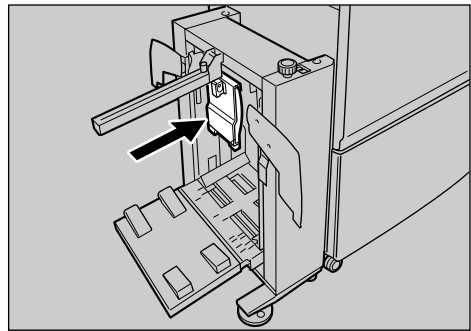

AJK163S

2

**Printing on 81.4 g/m<sup>2</sup> (21.6 lb.) or Heavier Paper**

- 1** Lower the paper alignment wings.

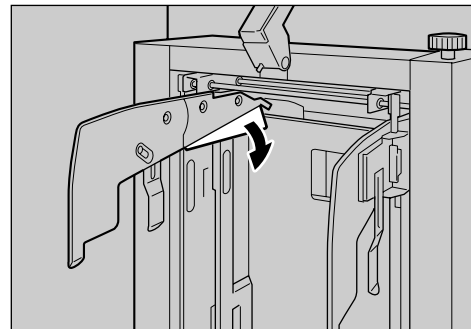

ABQ023S

**Note**

- Depending on the type of paper that you are using, you might not be able to use the full capacity (3000 sheets) of the LCOT when the wings are lifted.
- Lift the paper alignment wings when B5 JIS  or A4  prints are delivered curled up.

## Printing on Sizes Smaller than A4 or 8<sup>1</sup>/<sub>2</sub>" × 11" Paper

- 1 Swing out the guides as shown in the illustration.

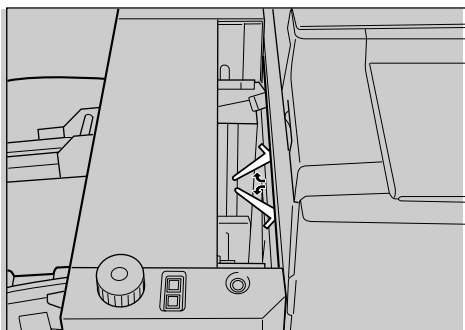

AJK311S

2

## Removing Prints

- 1 Move the side guides outward, and then lift the end plate arm.

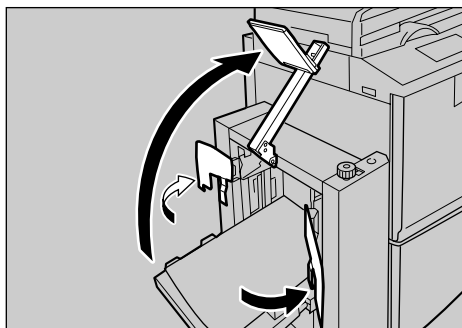

AJK164S

### Note

- Lift the end plate arm completely before releasing it.

- 2 Remove prints.

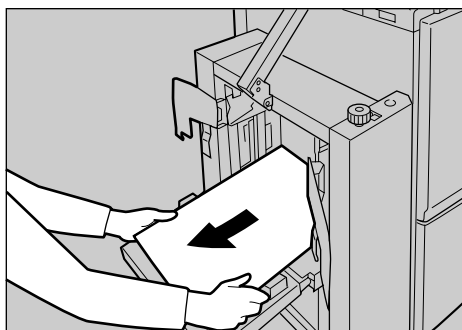

ABQ027S

- 3 Move the side guides and end plate arm back to their original positions.

### Note

- Lower the end plate arm completely before releasing it.

# After Printing

This section shows you how to return the paper feed tray and paper delivery tray to their original positions.

## Folding the Paper Feed Tray and Delivery Tray

### Folding the Paper Feed Tray

- 1 Remove the paper from the tray.

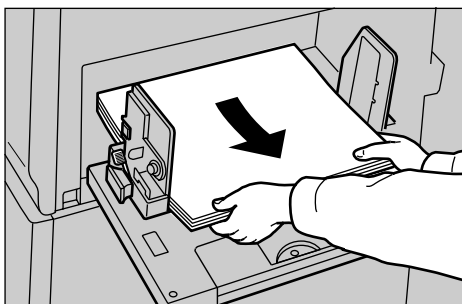

ACY009S

The paper feed tray will lower.

**Note**

- If the extender has been slid out, push it back.

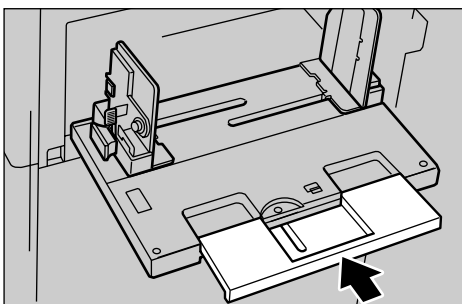

ACY010S

- 2 After the paper feed tray has stopped moving, raise the paper feed side plates knob lock lever to release the side plates.

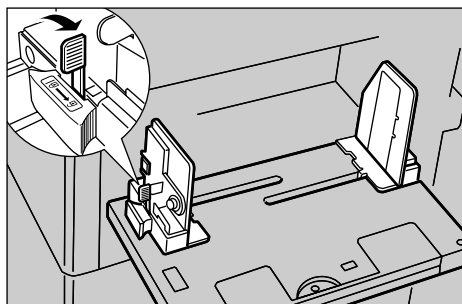

ACY011S

- 3 Adjust the side plates to A4, and then lower them.

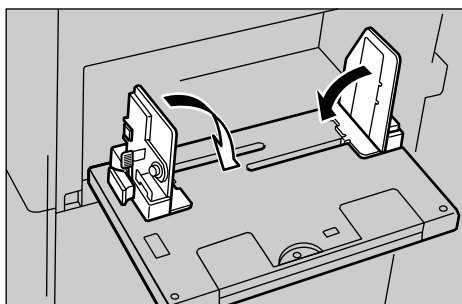

ACY012S

- 4 Gently close the paper feed tray.

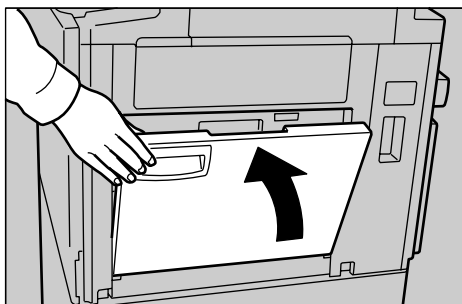

ACY013S

2

## Folding the Paper Delivery Tray

**1** Slightly lower one of the side plates.

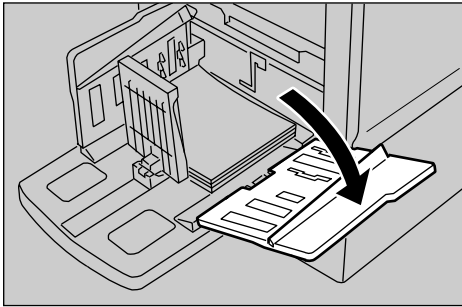

ACY050S

**2** Remove the prints from the tray.

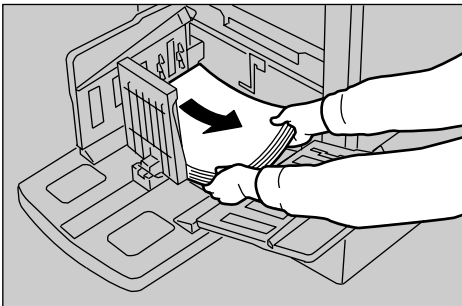

ACY051S

**3** Lower the paper alignment wings.

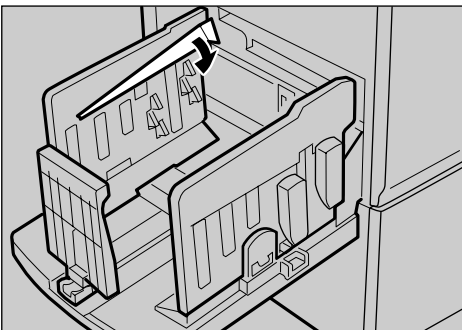

ACY059S

**4** Slide the chocks down.

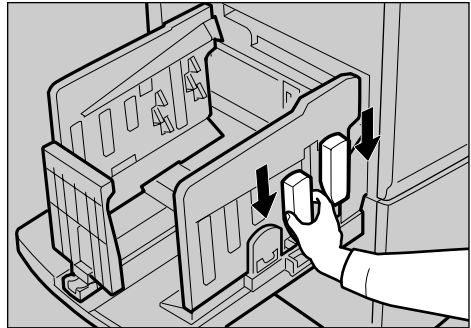

ACY060S

**5** Move the paper delivery end plate until its handle is flush with the end of the tray.

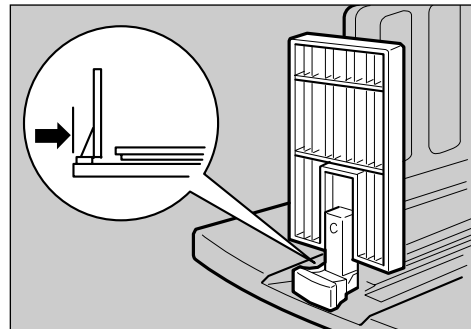

ZFRH190E

**6** Lower the paper delivery end plate.

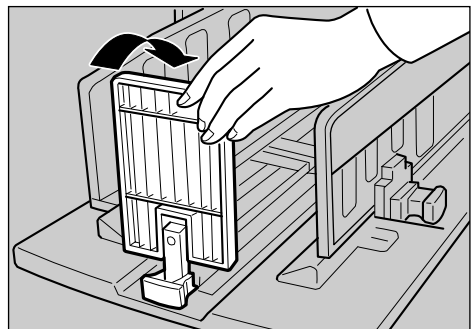

ABL054S

- 7** Move the side plates to the widest position, and then lower them.

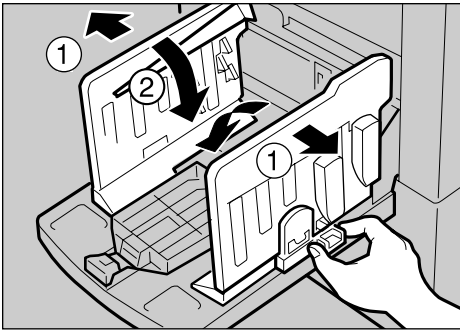

ACY065S

- 4** While pulling the LCIT release lever, detach the LCIT.

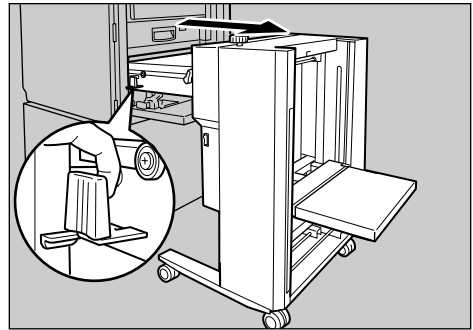

ABO009S

2

- 8** Close the paper delivery tray.

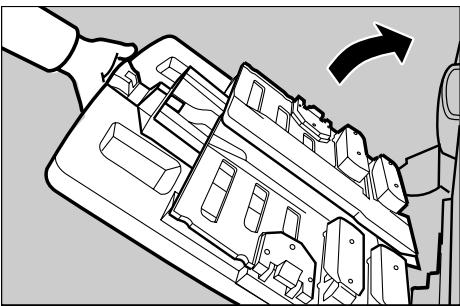

ABL023S

**Note**

- Be sure to hold the handle of the intermediate feeding section when you detach the LCIT.

- 5** Fold the intermediate feeding section.

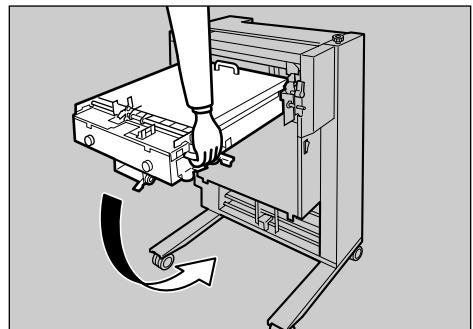

ABO010S

## Uninstalling the LCIT

- 1** Turn off the main switch of the machine, and then turn off the power switch of the LCIT.
- 2** Unplug the power cord of the LCIT from the wall outlet.
- 3** Unplug the LCIT optical cable.

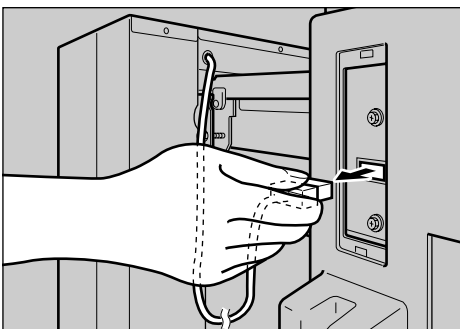

ACY067S

# Placing Originals

## Original Orientation

When using the ADF, place the originals face up.

When using the exposure glass, place the originals face down.

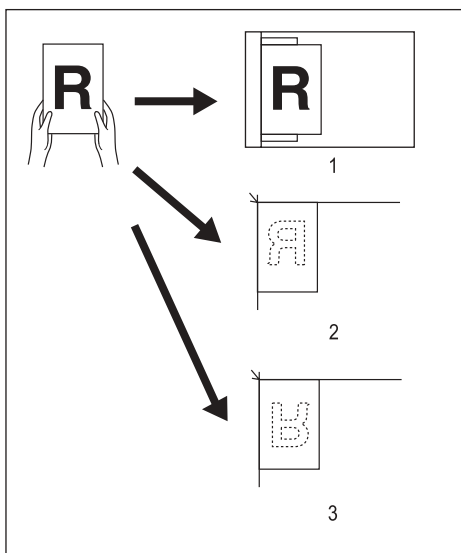

AJK307S

1. ADF
2. Exposure glass
3. Exposure glass (Combine, Stamp or Make-Up functions)

**Note**

When using the Combine, Stamp, or Make-Up functions, place the original face down with its leading edge towards you.

When printing A3 or B4 JIS or 11" x 17" size originals, select  as the Original Orientation. The machine will then rotate the print image by 90°. This is useful for printing large originals using the Combine, or Stamp functions.

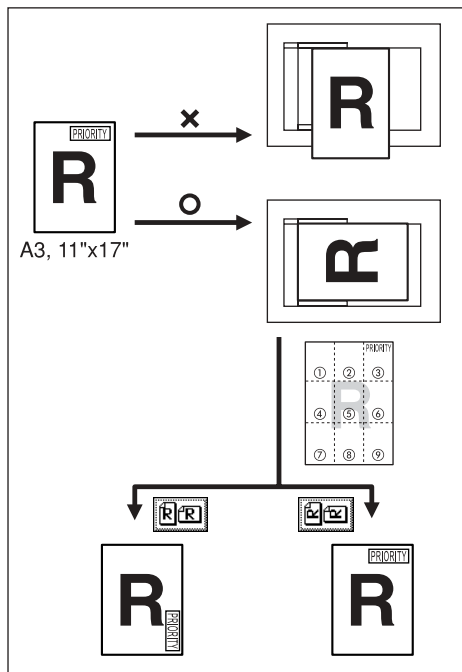

For example, to print A3 or 11" x 17" originals with the Stamp function selected:



AJK300S

**Note**

It is recommended that you use the Original Orientation function with the Auto Paper Select or Preset Reduce/Enlarge function.

- 1 Select  or 

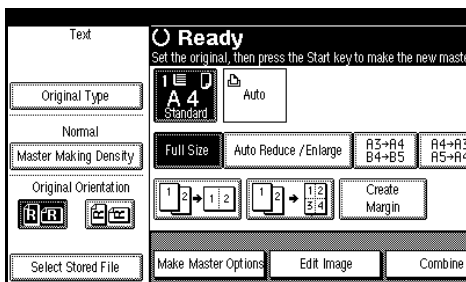

## Placing Originals on the Exposure Glass

- 1 Lift the exposure glass cover.

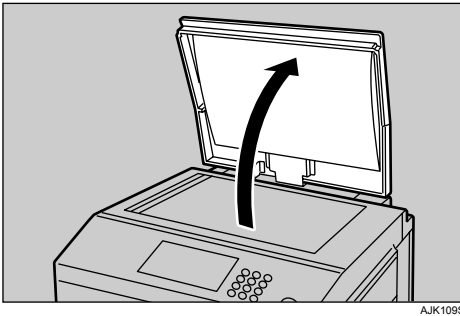

AJK109S

### Note

- ❑ Be sure to lift the exposure glass cover more than 30 degrees.

- 2 Place the original face down on the exposure glass. The original should be aligned with the left scale.

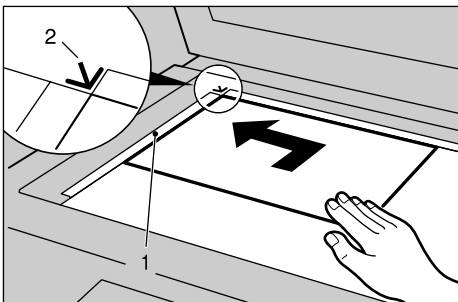

ACY058S

1. Left scale
  2. Positioning mark
- 3 Lower the exposure glass cover.

## Placing Originals in the Auto Document Feeder

- 1 Adjust the guide to the original size.
- 2 Insert the aligned originals face up into the ADF.

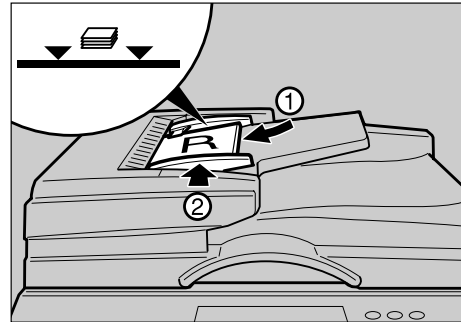

AJK153S

### Note

- ❑ To avoid originals misfeeding, fan the originals before placing them in the ADF.

### Limitation

- ❑ Approximately 50 originals (80 g/m<sup>2</sup>, 20 lb) can be inserted at a time in the ADF. The first (top) original will be fed first.

### Note

- ❑ To avoid jamming, fan the originals before placing them in the ADF.
- ❑ The guides must fit snugly against both sides of the stack.

- 3 Adjust print settings as necessary, and then press the [Start] key.

### Note

- ❑ If the next original has been placed in the ADF before the machine stops, that original is fed automatically.

## Basic Procedure

When Auto Cycle mode is on, you can process masters and make prints in a single operation.

### Note

- The Auto Cycle mode is set to “on” as default.
- For details about step-by-step master and print making, see p.49 “Making a Master and Prints”.

### 1 Make sure "Ready" appears on the display.

#### ❖ Initial print display

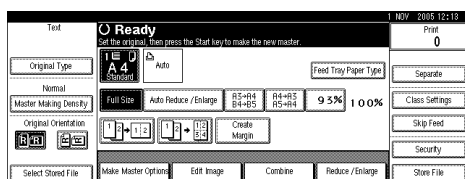

### Note

- If the machine has user codes set, enter your user code using the number keys, and then press [#].

### Reference

p.162 “User Code”

### 2 Make sure no previous settings remain.

#### Note

- If previous settings remain, press the **[Clear Modes]** key before entering your settings.

#### Note

- Check the **[Auto Cycle]** mode select key is lit.

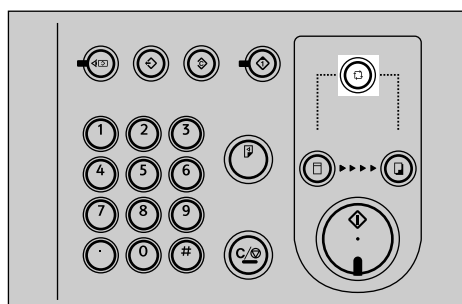

AJK105S

### 3 Place the originals.

#### Reference

p.42 “Placing Originals”

### 4 Make the necessary settings.

### 5 Enter the required number of prints using the number keys.

#### Note

- Set a print quantity between 1 (minimum) and 9999 (maximum).



## 6 Press the **[Start]** key.

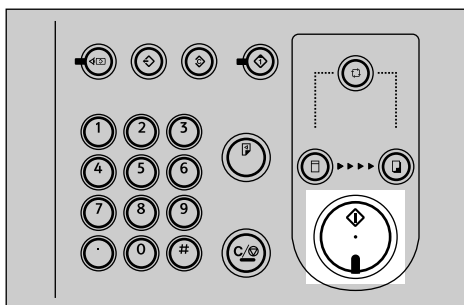

AJK10BS

Master making and printing starts.

### How to operate

❖ **To stop the machine during a multi-print run**

Press the **[Clear/Stop]** key.

❖ **To return the machine to the initial condition after printing**

Press the **[Clear Modes]** key.

❖ **When clearing entered values**

Press the **[Clear/Stop]** key or **[Clear]** on the display.

❖ **To check the settings**

Press the **[Check Modes]** key.

## Original Beeper

The beeper sounds and an error message is displayed if you leave originals on the exposure glass after printing.

## Auto Reset

If not used for a certain period of time after printing, the machine will return to the initial condition. This function is called "Auto Reset".

### Note

- You can change the time the machine waits before Auto Reset starts. See p.153 "System Auto Reset Timer".
- The machine will not enter Auto Reset in the following cases if:
  - a warning message appears
  - there is no ink
  - originals or paper are jammed
  - it is making master or printing
  - it is printing the second page of a combined print job
  - it is loading original images into memory
  - you are making changes with User Tools
  - there is no paper
  - there is no master
  - the paper delivery box is full
  - originals are left in the ADF
  - a cover is open
  - you select "Off" for "System Auto Reset Timer" with User Tools

## Saving Energy

If not used for a certain period of time after printing, the machine will enter the Energy Saver or Auto Off mode to reduce energy consumption.

### ❖ Energy Saver mode

The display goes off. Printing from a computer is possible in this mode.

To operate the machine, press the Operation switch, or place originals on the exposure glass or in the ADF.

To go back into the Energy Saver mode, press the Operation switch.

### ❖ Auto Off mode

The machine turns off automatically. To use it, turn the main switch on.

#### Note

- ❑ You can select which mode the machine enters after a specified period has passed following job completion. See p.154 “Energy Saver Option”.
- ❑ You can change the time the machine waits before Energy Saver or Auto Off mode starts. See p.153 “Energy Saver Timer”.

#### Note

- ❑ The machine will not automatically enter the Energy Saver or Auto Off mode in the following cases if:
  - a warning message appears
  - there is no ink
  - originals or paper are jammed
  - it is making master or printing
  - it is loading original images into memory
  - there is no paper
  - there is no master
  - originals are left in the ADF
  - a cover is open
  - you are making changes with User Tools
  - the user code entry screen is displayed
  - the Data In indicator is lit or blinking

## Auto Off Timer

You can set the machine to turn itself off at a specified time everyday.

Make the timer setting in User Tools. See p.153 “Auto Off Timer”.

#### Note

- ❑ The machine will not automatically turn itself off if you are using it at the set time.

# Printing onto Various Kinds of Paper

Before printing onto thick paper, thin paper, envelopes or special kinds of paper loaded in the paper feed tray, you must select the paper type.

## Printing onto Thick Paper

If you wish to print onto thick (128 to 209.3 g/m<sup>2</sup>, 34 to 55.6 lb or heavier) paper, perform the following steps.

- 1 Press [Feed Tray Paper Type].

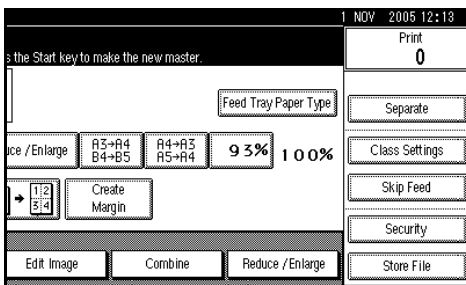

- 2 Press [Thick Paper].
- 3 Press [Change Settings].
- 4 Press [OK].

## Printing onto Standard Paper

If you wish to print onto standard (47.1 to 105 g/m<sup>2</sup>, 12.5 to 28 lb) paper, perform the following steps.

- 1 Press [Feed Tray Paper Type].
- 2 Make sure that [Normal] is selected.
- 3 Press [OK].

## Printing onto Envelopes

- 1 Press [Feed Tray Paper Type].
- 2 Select [Special Paper].
- 3 Press [Change Settings].
- 4 Press [OK].
- 5 Place the envelopes in the paper feed tray as shown in the illustration.

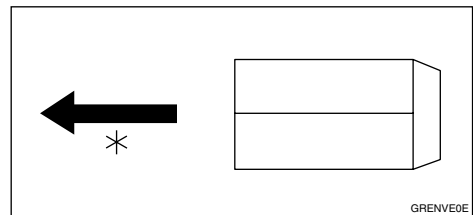

\* Paper feed direction

### Note

- When you use envelopes, the paper feed tray capacity is about 150 sheets (85 g/m<sup>2</sup>, 22 lb) or enough to load a stack up to 105 mm, 4.1" high.

- 6 If your envelopes do not feed in well, lift the paper feed tray a little, and then lower it so that it slants up slightly.

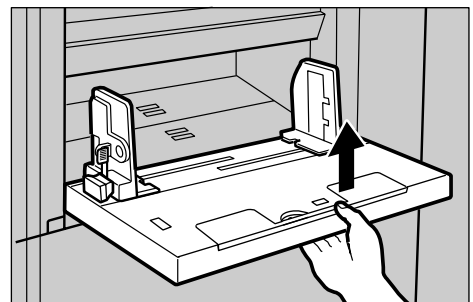

ZDZV030E

## Printing onto Special Paper

### Preparation

To use this function, you have to register the special paper type in **[User 1]**, or **[User 2]** with User Tools. See p.155 “Paper Type: User1–2”.

**1** Press **[Feed Tray Paper Type]**.

**2** Select **[User 1]** or **[User 2]**.

**3** Press **[Change Settings]**

**4** Press **[OK]**.

# Making a Master and Prints

Using the default settings, you can process masters and make prints in a single operation. This is called "Auto Cycle". You can also make masters and prints in separate operations. See the procedure below.

## Note

- To create masters and make prints in a single operation, see p.44 "Basic Procedure".

## 1 Make sure the [Master Making] mode select key is lit.

### Note

- If it is not lit, press the [Master Making] mode select key.

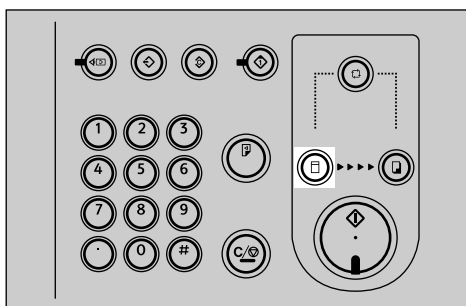

AJK108S

## 2 Place your originals.

### Reference

p.42 "Placing Originals"

## 3 Press the [Start] key.

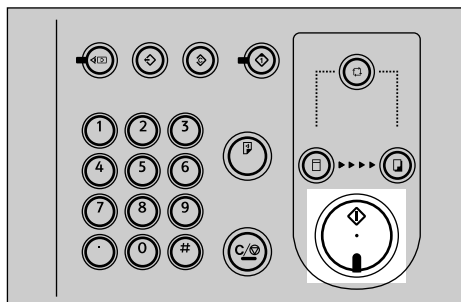

AJK108S

### Note

- Press the [Proof] key to check the image before making prints.

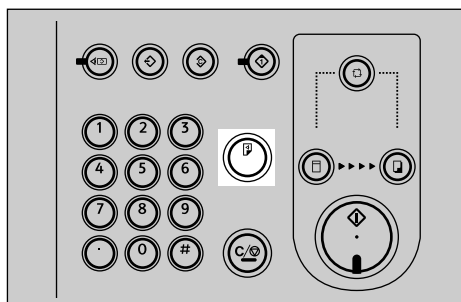

AJK108S

### Reference

To change the image position, see p.54 "Adjusting the Position of Printed Images".

## 4 Make sure the [Print] mode select key is lit.

- 5** Enter the required number of prints using the number keys.

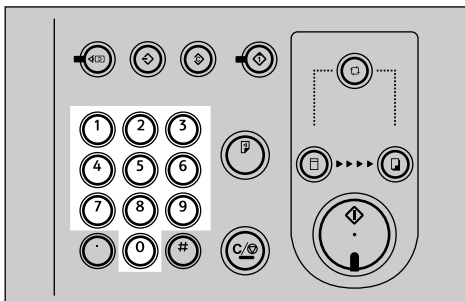

AJK108S

- 6** Press the **[Start]** key.

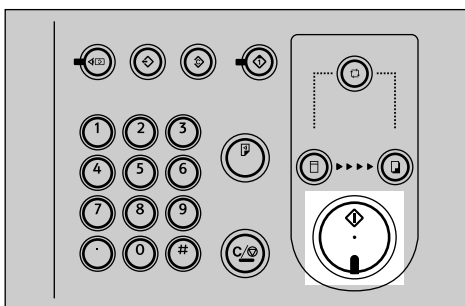

AJK108S

When the print job finishes, press the **[Clear Modes]** key. Previously entered job settings are cleared.

## Selecting Cycle Setting

When printing from a computer, one of the four master making and printing cycles listed below can be selected. For details about Cycle Settings, see *Printer Reference*.

- Auto Cycle
- Original Page Cycle
- Master Cycle
- Master/Print Cycle

## Image Rotation

When your original setting orientation is different from the paper orientation, the machine automatically rotates the original image by 90° to match the paper orientation.

### Note

- ☐ The following tables list the combinations that can be used in Image Rotation mode.

#### ❖ Metric version

Original Paper	A3☐	B4 JIS☐	A4☐	A4☐	B5 JIS☐	B5 JIS☐	A5☐☆	A5☐☆
A4☐	--	--	--	★	--	★	--	★
A4☐	★	★	★	--	★	--	★	--
B5 JIS☐	--	--	--	★	--	★	--	★
B5 JIS☐	★	★	★	--	★	--	★	--
A5☐	--	--	--	★	--	★	--	★
B6 JIS☐	--	--	--	★	--	★	--	★

★: The machine automatically rotates the original image by 90° to match the paper orientation.

☆: Place these originals in the optional ADF.

#### ❖ Inch version

Original Paper	11" × 17"☐	8½" × 14"☐	8½" × 11"☐	8½" × 11"☐	5½" × 8½"☐☆	5½" × 8½" ☐☆
8½" × 11"☐	--	--	--	★	--	★
8½" × 11"☐	★	★	★	--	★	--
5½" × 8½"☐	--	--	--	★	--	★

★: The machine automatically rotates the original image by 90° to match the paper orientation.

☆: Place these originals in the optional ADF.

### Note

- ☐ If you use Zoom mode, custom size originals or paper, the image will not be rotated.
- ☐ It takes longer than usual to make masters in Image Rotation mode.
- ☐ You can cancel Image Rotation mode with User Tools. See p.161 "Auto Rotation".

## Selecting Original Type

The following can be selected as the original document type.

### ❖ Text

Specify this if the original document consists primarily of text.

### ❖ Text/Photo

If the original document contains a combination of text and photographs, it is printed using the optimum image balance.

#### Note

- Contrast can be selected.

### ❖ Photo

Specify this for photographs, pictures, or coloured documents.

#### Note

- Contrast and screen can be selected.

### ❖ Pencil

Specify this for originals drawn/written in pencil.

#### Note

- Set documents drawn/written in pencil on the exposure glass.

### ❖ Pale

When printing pale colours, the master is created using pale colour print.

#### Note

- Masters are normally produced using **[Text]**.
- If **[Photo]** is selected for original documents that contain both text and photographs, text may appear too light. If this is the case, select **[Text / Photo]**.
- Black ink printed using **[Pale]** can produce a grayish colour.
- Coloured ink printed using **[Pale]** can produce pale colours for background images.

### 1 Press **[Original Type]**.

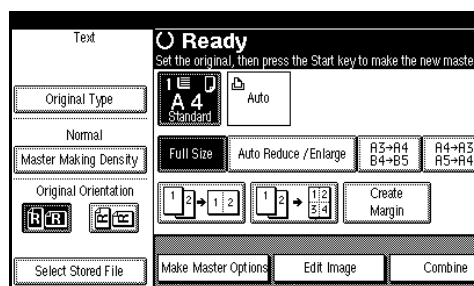



## 2 Select the type of original.

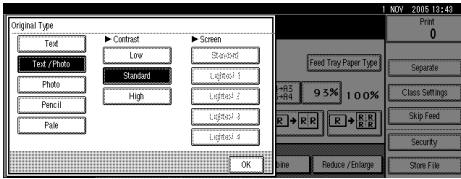

Adjust the contrast in the **[Text / Photo]** and **[Photo]** modes.

### Note

- Contrast adjustment is effective only if the **[Text / Photo]** or **[Photo]** mode is selected.
  - When **[High]** is selected, human faces are sharpened.
  - When **[Low]** is selected, scenery and other similar images are sharpened.

Adjust the screen in the **[Photo]** modes.

### Note

- Screen adjustment is effective only if the **[Photo]** mode is selected.
- Screen can be selected in five levels, **[Standard]**, **[Lightest 1]**, **[Lightest 2]**, **[Lightest 3]** and **[Lightest 4]**.

## 3 Press [OK].

## Master Making Density

You can adjust the print image density before making a master in the following cases.

- When printing from faint originals, set the image density darker.
- When printing from originals that have many fine lines, set the image density darker.
- When printing from originals that have many bold lines or blurred letters, set the image density lighter.

## 1 Press [Master Making Density].

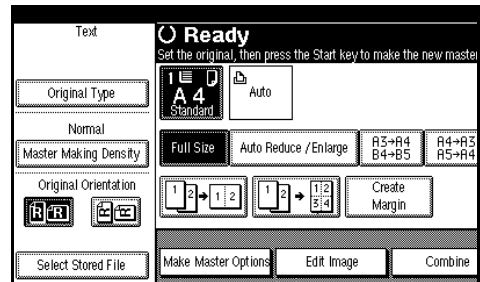

## 2 Select the density, and then press [OK].

### Note

- Density can be selected in four levels, **[Light]**, **[Normal]**, **[Dark]** and **[Very Dark]**.
- To darken the density, select **[Dark]** or **[Very Dark]**, and to lighten the density, select **[Light]**.

## Sample Print and Adjustment

Once the master making has been completed, it is possible to confirm the print finish before pressing the **[Print]** mode select key to start the printing process.

2

### Note

- ❑ After completing the master making, it is only possible to adjust the print position and speed

### 1 Press the **[Proof]** key.

#### Note

- ❑ You can also use the **[Proof]** key arranged in the right part of the control panel.

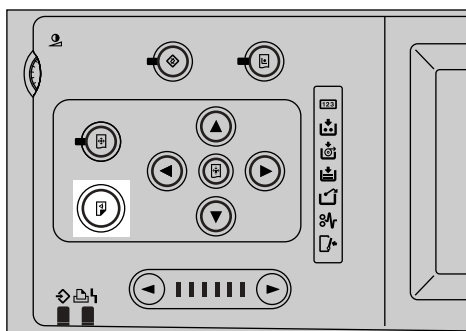

AJK138S

A single printed page is ejected.

#### Note

- ❑ Press the key continuously to eject printed pages in succession.

## Adjusting the Position of Printed Images

Use the following procedure to adjust the position of print images as required.

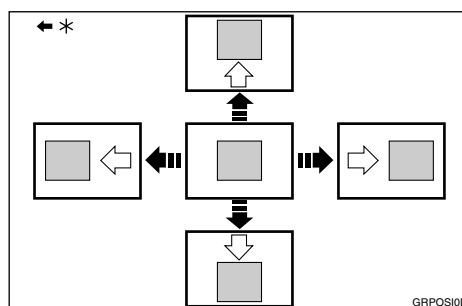

GRPOS10E

\* Paper feed direction

### 1 Press **[Image position]**.

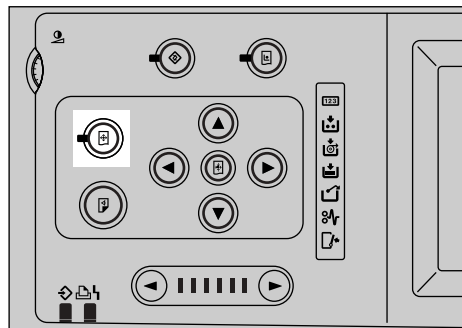

AJK137S

- 2** Adjust image position using the [▼], [▲], [▶], and [◀] keys.

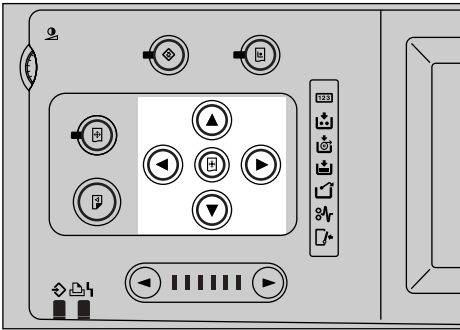

**Note**

- ❑ When you shift the image forward, leave a 10 mm, 0.4" margin at the leading edge. If there is no margin, paper might wrap around the drum and cause a misfeed.
- ❑ One push of either scroll key shifts the image position by 0.25 mm, 0.01".
- ❑ The [▼] and [▲] keys shift the image up to 10 mm, 0.4" in each direction.
- ❑ The [▶] and [◀] keys shift the image up to 15 mm, 0.6" in each direction.
- ❑ When you reset to the default position, press the **[Initial position]** key.

- 3** Press [Exit].

- 4** Press the **[Proof]** key to check the image position.

## Changing the Printing Speed

Use the [◀] or [▶] key to adjust the printing speed. The relationship between printing speed and print quality depends on the type of paper you use.

**Limitation**

- ❑ When printing on paper longer than 364 mm or 14.4", the maximum print speed is 120 sheets/minute.

- 1** Press the [▶] key to increase the speed, or the [◀] key to reduce the speed.

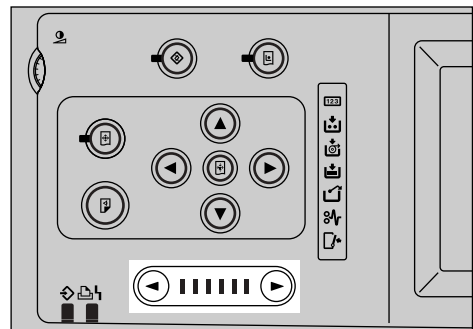

The printing speed changes in six increments as follows:

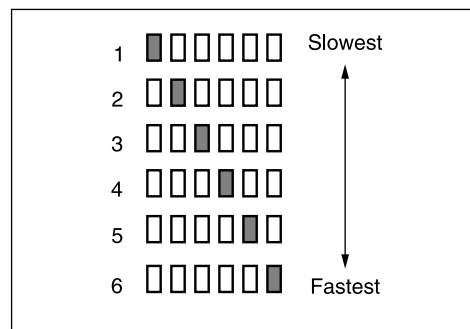

1. 60 sheets/minute
2. 75 sheets/minute
3. 90 sheets/minute
4. 105 sheets/minute
5. 120 sheets/minute
6. 135 sheets/minute



# 3. Printing Functions

## Printing Functions

### Preset Reduce/Enlarge

Use this function to reduce or enlarge originals by a preset ratio. A total of 9 ratios are available (3 enlargement ratios, 6 reduction ratios).

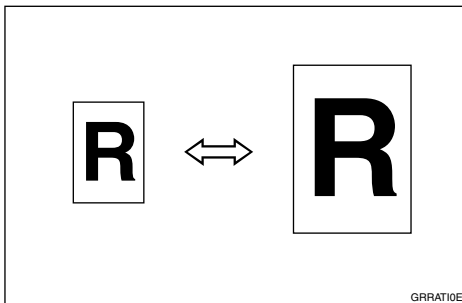

#### Note

- You can select a ratio regardless of the size of an original or printing paper. With some ratios, parts of the image might not be printed or margins will appear on prints.
- You can change the preset reproduction ratios with User Tools. See p.158 "Reproduction Ratio".
- Prints can be reduced or enlarged as follows:

#### ❖ Metric version

Ratio (%)	Original → Print paper size
200	A5 → A3, B6 JIS → B4 JIS
141	A4 → A3, A5 → A4
122	A4 → B4 JIS, A5 → B5 JIS
115	B4 JIS → A3, B5 JIS → A4
93	—
87	A3 → B4 JIS, A4 → B5 JIS
82	B4 JIS → A4, B5 JIS → A5
71	A3 → A4, B4 JIS → B5 JIS,
61	A3 → B5 JIS, A4 → B6 JIS
50	A3 → A5, B4 JIS → B6 JIS

#### ❖ Inch version

Ratio (%)	Original → Print paper size
200	5 1/2" × 8 1/2" → 11" × 17"
155	5 1/2" × 8 1/2" → 8 1/2" × 14"
129	8 1/2" × 11" → 11" × 17"
121	8 1/2" × 14" → 11" × 17"
93	—
85	F → 8 1/2" × 11"
77	8 1/2" × 14" → 8 1/2" × 11"
74	11" × 15" → 8 1/2" × 11"
65	11" × 17" → 8 1/2" × 11"
50	11" × 17" → 5 1/2" × 8 1/2"

**1** Place the originals.

**2** Press [Reduce / Enlarge].

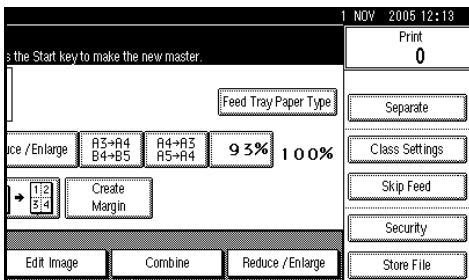

**Note**

To select a preset ratio on the initial display, press the shortcut Reduce/Enlarge key, and then proceed to step **3**.

**3** Press [Enlarge] or [Reduce].

**4** Select a ratio, and then press [OK].

**5** Press the [Start] key.

## Zoom

You can change the reproduction ratio in increments of 1%.

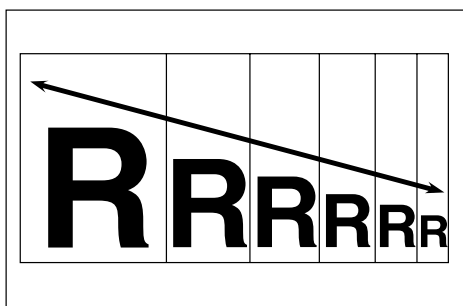

**Note**

You can select a preset ratio close to the ratio using [Reduce] or [Enlarge], and then adjust it further, using [+ ] or [- ].

**1** Place the originals.

**2** Press [Reduce / Enlarge].

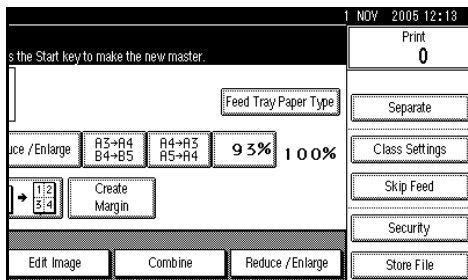

**3** Enter the ratio.

To select the ratio using [+ ] and [- ]

**1** Select a preset ratio close to the ratio using [Reduce] or [Enlarge].

**2** Adjust the ratio further, using [+ ] or [- ].

**Note**

Pressing [+ ] or [- ] changes the ratio in increments of 1%. Pressing and holding down [+ ] or [- ] changes it in increments of 10%.

If you have incorrectly entered the ratio, readjust it using [+ ] or [- ].

To enter the ratio using the number keys

**1** Press [Mag. Ratio].

**2** Enter the ratio using the number keys.

**3** Press [#].

**4** Press [OK].

**4** Press the [Start] key.

## Auto Reduce/Enlarge

The machine can choose an appropriate reproduction ratio based on the paper and original sizes you select.

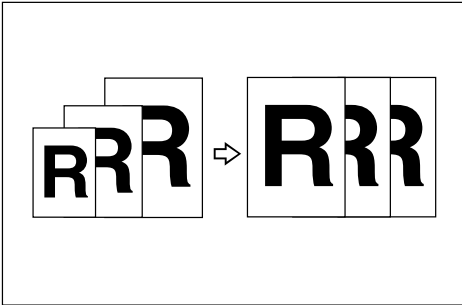

### Note

- ❑ The range of ratios you can select are 50 – 200%.
- ❑ The table below shows the reproduction ratios that can be selected for various combinations of original and paper size.

#### ❖ Metric version

Original Paper	A3	B4 JIS	A4	A4	B5 JIS	B5 JIS	A5 <sup>*2</sup>	A5 <sup>*2</sup>
A3	100%	115%	141%	--	163%	--	200%	--
B4 JIS	87%	100%	122%	--	141%	--	173%	--
A4	71%	82%	100%	100% <sup>*1</sup>	115%	115% <sup>*1</sup>	141%	141% <sup>*1</sup>
A4	71% <sup>*1</sup>	82% <sup>*1</sup>	100% <sup>*1</sup>	100%	115% <sup>*1</sup>	115%	141% <sup>*1</sup>	141%
B5 JIS	61%	71%	87%	87% <sup>*1</sup>	100%	100% <sup>*1</sup>	122%	122% <sup>*1</sup>
B5 JIS	61% <sup>*1</sup>	71% <sup>*1</sup>	87% <sup>*1</sup>	87%	100% <sup>*1</sup>	100%	122% <sup>*1</sup>	122%
A5	50%	50%	71%	71% <sup>*1</sup>	82%	82% <sup>*1</sup>	100%	100% <sup>*1</sup>
B6 JIS	--	50%	61%	61% <sup>*1</sup>	71%	71% <sup>*1</sup>	87%	87% <sup>*1</sup>

<sup>\*1</sup> The machine automatically rotates the original image by 90° to match the paper direction and selects an appropriate reproduction ratio. See p.51 “Image Rotation”.

<sup>\*2</sup> Place these originals in the optional ADF.

❖ Inch version

Original Paper	11" × 17" □	8½" × 14" □	8½" × 11" □	8½" × 11" □	8½" × 5½" □ *2	8½" × 5½" □ *2
11" × 17" □	100%	121%	129%	--	200%	--
8½" × 14" □	77%	100%	--	--	155%	--
8½" × 11" □	65%	77%	100%	100% *1	129%	129% *1
8½" × 11" □	65% *1	77% *1	100% *1	100%	129% *1	129%
8½" × 5½" □	50%	61%	65%	65% *1	100%	100% *1

\*1 The machine automatically rotates the original image by 90° to match the paper direction and selects an appropriate reproduction ratio. See p.51 "Image Rotation".

\*2 Place these originals in the optional ADF.

**1** Place the originals.

**2** Press [Auto Reduce / Enlarge].

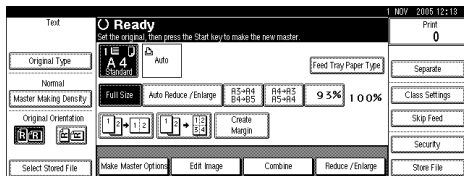

**3** Press the [Start] key.



## Directional Magnification (%)

Prints can be reduced or enlarged at different reproduction ratios, horizontally and vertically.

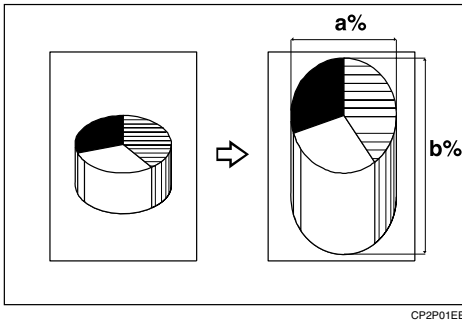

CP2P01EE

a: Horizontal ratio

b: Vertical ratio

### Note

- You can also select a preset ratio close to the ratio using **[Reduce]** or **[Enlarge]**, and then adjust it further, using **[+]** or **[-]**.

**1** Place the originals.

**2** Press **[Reduce / Enlarge]**.

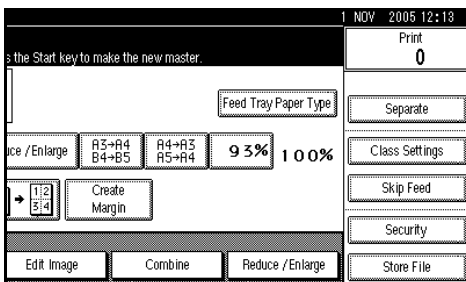

**3** Press **[Specified Ratio]**.

**4** Press **[Direct. Mag.%]**.

To enter the ratio using the number keys

- 1** Press **[Horizontal]**.
- 2** Enter the ratio using the number keys, and then press **[#]**.
- 3** Press **[Vertical]**.
- 4** Enter the ratio using the number keys, and then press **[#]**.
- 5** Press **[OK]**.

To specify a ratio using **[+]** and **[-]**

- 1** Press **[With +-]**.
- 2** Press **[Horizontal]**.
- 3** Adjust the ratio using **[+]** or **[-]**.

### Note

- Pressing **[+]** or **[-]** changes the ratio in increments of 1%. Pressing and holding down **[+]** or **[-]** changes it in increments of 10%.

- If you have incorrectly entered the ratio, readjust it using **[+]** or **[-]**.

**4** Press **[Vertical]**.

**5** Adjust the ratio using **[+]** or **[-]**.

**6** Press **[OK]**.

**5** Press **[OK]**.

**6** Press the **[Start]** key.

## Directional Size Magnification (mm)

A suitable reproduction ratio is automatically selected when you enter the horizontal and vertical lengths of the original and print image you require.

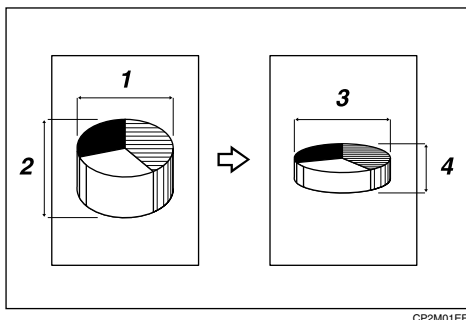

1. Horizontal original size
2. Vertical original size
3. Horizontal print size
4. Vertical print size

### Preparation

Specify the vertical and horizontal size of the original and that of the prints, as shown.

### Note

- You can enter sizes within the following ranges:

Metric version	Vertical: 1–999 mm (increments of 1 mm) Horizontal: 1–999 mm (increments of 1 mm)
Inch version	0.1"–99.9" (increments of 0.1")

- 1 Place the originals.
- 2 Press [Reduce / Enlarge].

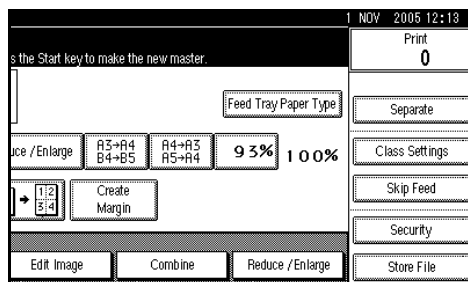

- 3 Press [Specified Ratio].
- 4 Press [Direct. Mag. mm].
- 5 Enter the horizontal size of the original using the number keys, and then press [#].
- 6 Enter the horizontal size of the print using the number keys, and then press [#].
- 7 Enter the vertical size of the original using the number keys, and then press [#].
- 8 Enter the vertical size of the print using the number keys, and then press [#].

### Note

- To change the length, press the key you want to change, and then enter the new value.

- 9 Press [OK] twice.
- 10 Press the [Start] key.

## Combine

Use this function to combine originals onto one sheet of paper.

### ❖ 2 one-sided originals

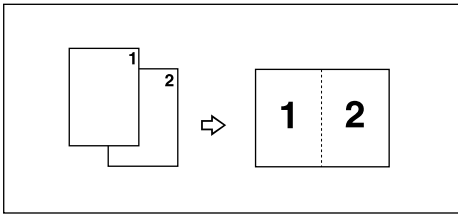

### ❖ 4 one-sided originals

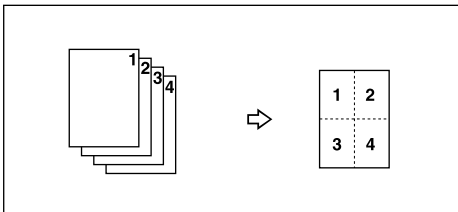















### Preparation

You can combine 2 or 4 one-sided originals onto one side of a sheet.

Refer to the following tables when you select the original and paper sizes:

#### ❖ Metric version

Original Paper	A3 	B4 JIS 	A4  	B5 JIS  	A5   *3
A3 	*2	*2	*2	*2	*2
B4 JIS 	*1	*2	*2	*2	*2
A4  	*1	*1	*2	*2	*2
B5 JIS   	–	*1	*1	*2	*2

\*1: You can use these original and paper sizes to combine 4 one-sided originals.

\*2: You can use these original and paper sizes to combine 2 or 4 one-sided originals.

\*3: Only available when placing the original on the exposure glass.

❖ **Inch version**

Original Paper	11" × 17"	8 1/2" × 14"	8 1/2" × 11"	5 1/2" × 8 1/2"   *3
11" × 17"	*2	*2	*2	*2
8 1/2" × 14"	*1	*2	*2	*2
8 1/2" × 11"	*1	*1	*2	*2
5 1/2" × 8 1/2"	–	–	*1	*2

\*1: You can use these original and paper sizes to combine 4 one-sided originals.

\*2: You can use these original and paper sizes to combine 2 or 4 one-sided originals.

\*3: Only available when placing the original on the exposure glass.

**Limitation**

- You cannot print with originals different in size and orientation.
- If the reproduction ratio is under 49%, it is automatically adjusted to 50%. Parts of the image might not be printed.

**Note**

- You can print a separation line in between the combined images. See p.159 "Combine/Image Repeat Separation Line".
- You can set the machine to automatically cancel Combine mode once you have finished using it. See p.160 "Cancel Combine/Repeat Setting".
- If the orientation of originals is different from that of the paper, the machine will automatically rotate the image by 90° to make prints properly.
- If the number of originals placed is less than the number specified for combining, the last page segment is left blank as shown.

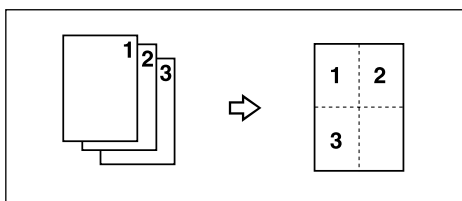

## 1 Place the originals.

Placing the original (☐) on the exposure glass

- 1 Place the original face down with its leading edge towards you, as shown below.

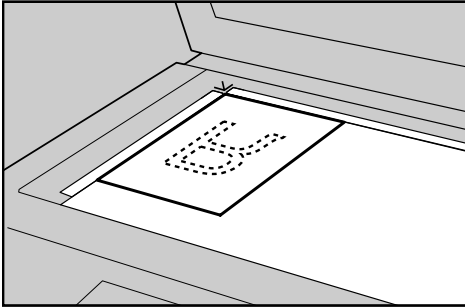

ZDCH110E

Placing the originals (☐) in the optional ADF

- 1 Place the originals face up with the first page on the top.
- 2 Adjust the document guides to the original size.

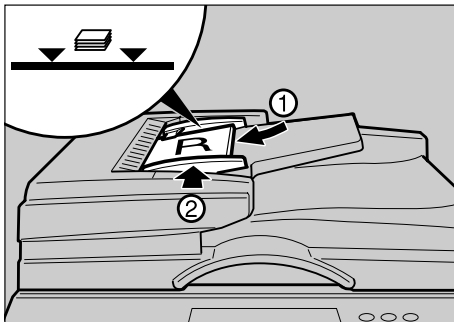

AJK153S

### Note

- ☐ To avoid originals misfeeding, fan the originals before placing them in the ADF.

**2** Press [Combine].

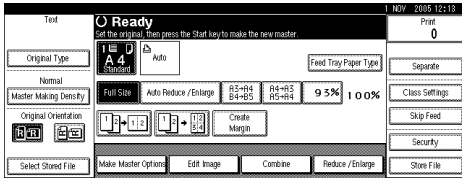

**3** Press [2 Originals ] or [4 Originals] .

**4** Press [OK].

**5** Press the [Start] key.

**Note**

- The machine selects the reproduction ratio automatically.
- When placing an original on the exposure glass or one sheet at a time in the optional ADF, repeat steps **1** and **5**. After placing the last original, press the [#] key.

## Class Settings

You can use the Class Setting function to make different numbers of prints for different classes from the same original. All stored numbers of prints are made for each set. You can also make the same number of prints for the same class from a number of different originals.

This feature is useful for teachers who frequently make multiple print sets (notes, handouts, tests etc) for their classes.

The following class function modes are available:

### ❖ Class mode

Make the same number of prints from the same original for multiple classes. You must enter the numbers of prints and classes.

You can set the multiple pattern of the number of prints and classes.

You can also register frequently used pattern settings in the machine's memory and recall these for future use.

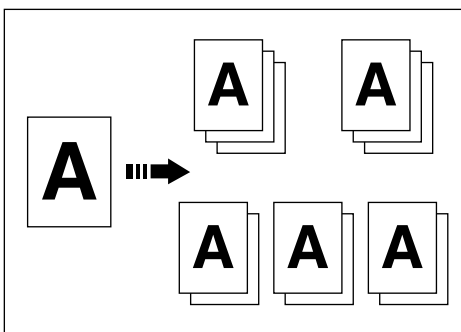

AJK210S

### ❖ Separate per Original mode

Make prints from different originals for multiple classes. You must enter the numbers of prints for each original manually.

You can also register frequently used settings of the numbers of originals and prints in the machine's memory and recall these for future use.

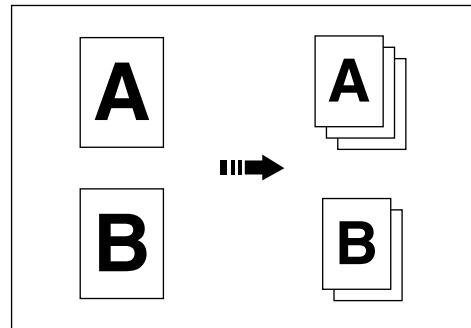

AJK211S

### ❖ Separate Prints

Make prints from the same original for multiple classes. You must enter the numbers of prints for each class manually.

You can also register frequently used settings of the numbers of prints in the machine's memory and recall these for future use.

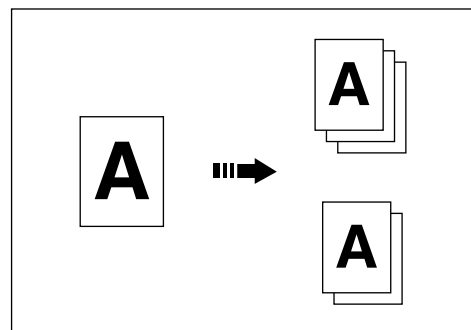

AJK212S

❖ **Year/Class**

Make prints from the same originals for all registered classes, years.

This mode allows you to store the number of students in each class in the machine's memory beforehand.

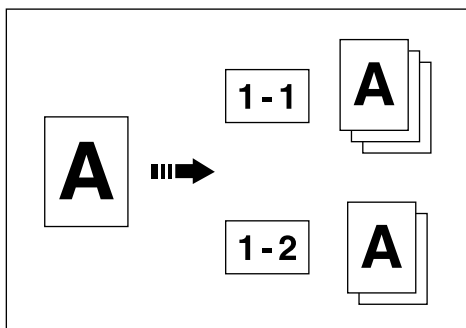

AJK213S

**Note**

- ❑ When you select the Class Setting function, Separate mode is automatically enabled. The Separator pulls the top sheet of each set delivered to the paper delivery tray to mark the end of each print set. See p.71 “Separate”.
- ❑ You can also cancel Separate mode with User Tools. See p.161 “Auto Separate (Class)”.

**Class mode**

**1** Place one original on the exposure glass or in the optional ADF.

**2** Press [Class Settings].

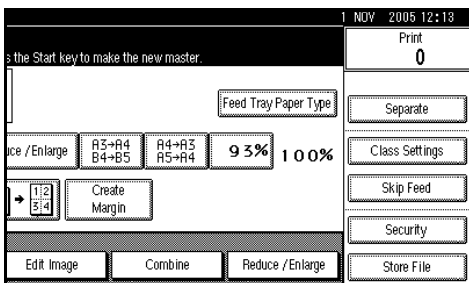

**3** Press [Class].

**4** Enter the number of prints and classes per pattern using the number keys, and then press the [#] key.

**Registering a program**

You can also register frequently used settings in machine memory.

**1** Press [Program / Recall].

**2** Press [Program].

**3** Press the program number you want to store.

**Note**

- ❑ Program numbers displayed with next to them already have settings.

**4** Enter the program name using the letter keys on the display panel.

You can enter up to 40 characters.

**Reference**

For details about entering characters, see p.175 “Entering Text” .

**5** Press [OK].

When the settings are successfully stored, the indicator followed by the program number and program name will be displayed. After a while, the screen reverts back to the initial display.



## Recalling a Program

You can recall the program if you have registered it already.

- 1 Press [Program / Recall].
- 2 Press [Recall].

The stored settings are displayed.

### Note

- Program numbers displayed with  next to them already have settings.

- 3 Press the number of the program you want to recall.

- 5 Press [OK] twice.

- 6 Press the [Start] key.

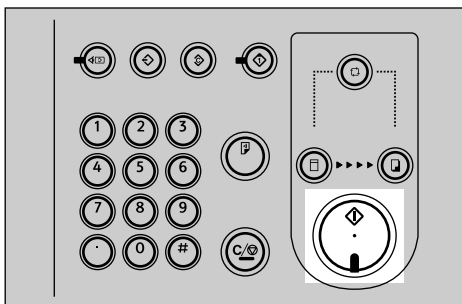

AJK108S

## Separate per Original

- 1 Place first original on the exposure glass or in the optional ADF.

- 2 Press [Class Settings].

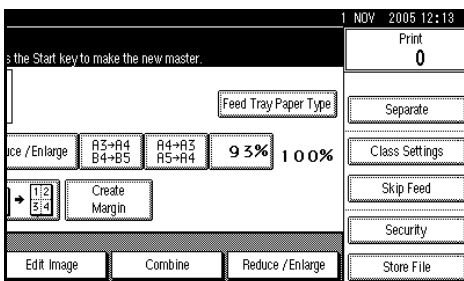

- 3 Press [Separate per Orig.].

- 4 Enter the number of prints per original using the number keys, and then press the [#] key.

### Note

- Up to 30 originals can be set.
- If you use this setting frequently you can register and recall a program. For details, see p.68 "Registering a program" and p.69 "Recalling a Program".

- 5 Press [OK] twice.

- 6 Press the [Start] key.

## Separate Prints

- 1 Place one original on the exposure glass or in the optional ADF.

- 2 Press [Class Settings].

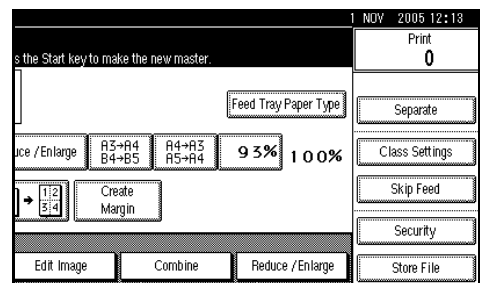

- 3 Press [Separate Prints].

- 4 Enter print quantity per number of class using the number keys, and then press the [#] key.

### Note

- Up to 30 classes can be set.
- If you use this setting frequently you can register and recall a program. See procedure of "Registering a Program" and "Recalling a Program" on p.68 "Class mode"

- 5 Press [OK] twice.

- 6 Press the [Start] key.

## Year/Class

### Preparation

You must register the number of students in each class. See p.70 “Registering Classes” .

**1** Place one original on the exposure glass or in the optional ADF.

**2** Press [Class Settings].

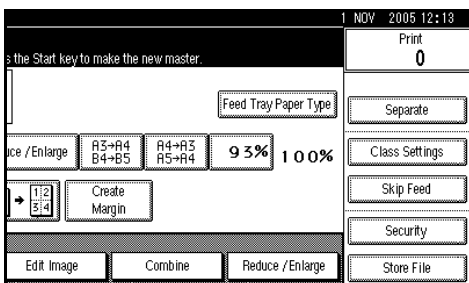

**3** Press [Year / Class].

**4** Press the registered class for each year you want.

### Note

- To select all classes of year, press [All] of the desired year.
- Make prints for all registered classes, press [All Years].

**5** Press [OK] twice.

**6** Press the [Start] key.

## Registering Classes

**1** Press [Class Settings].

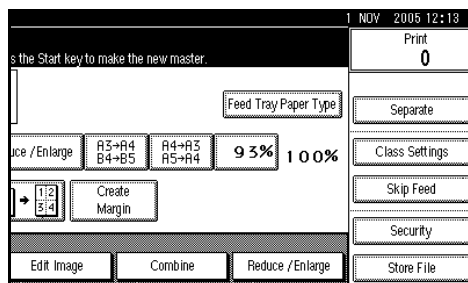

**2** Press [Year / Class].

**3** Press [Program / Change].

**4** Press the class number.

**5** Enter the number of students using the number keys, and then press the [#] key.

### Note

- Repeat steps **4** and **5** until you have finished registering the number of students in each class for each year.
- Up to 9 years and 12 classes for each year can be set

**6** Press [OK] twice.

## Separate

The print on the top of each print set in the paper delivery tray is pulled by the separator. This function is useful when you make two or more print sets.

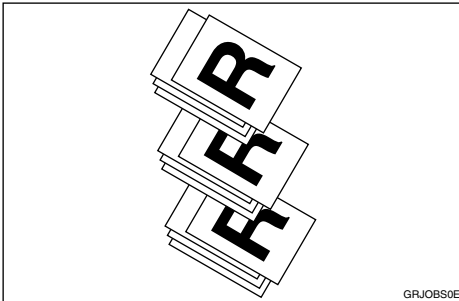

### Limitation

In Separate mode, the following limitations apply.

#### ❖ Metric version

Minimum paper size	Maximum paper weight	Paper delivery tray capacity	LCOT capacity
Length: 210 mm Width: 128 mm	127.9 g/m <sup>2</sup>	600 sheets (64 g/m <sup>2</sup> )	3000 sheets (64 g/m <sup>2</sup> )

#### ❖ Inch version

Minimum paper size	Maximum paper weight	Paper delivery tray capacity	LCOT capacity
Length: 8.3" Width: 5.1"	34 lb	600 sheets (17 lb)	3000 sheets (17 lb.)

### Note

- When you use thin paper, it is not recommended to use Separate mode. The separator might tear the paper.
- If the separator touches the print image, prints might be marked. In this case, it is not recommended to use Separate mode.
- When you do not use Separate mode, you can select the machine condition after each print set is fed out to the paper delivery tray with User Tools. See p.155 "Auto Class".
- If there are less than 10 sheets of paper in the paper delivery tray, the machine may not be able to use Separate mode.

**1** Place the originals.

**2** Press the [Separate] key.

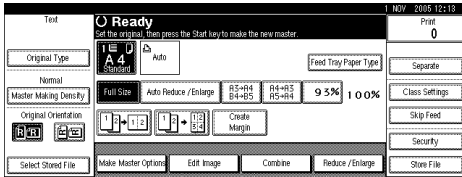

**3** Press the [Start] key.

**Note**

- After the last page of each print set is fed out to the paper delivery tray, the separator pulls the last sheet of each group in Separate mode. The next separation begins.

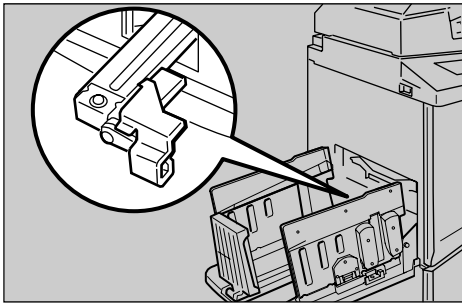

ACY039S

## Image Repeat

Use this function to repeat the image on the same sheet of paper. You can select to print 2, 4, 8 or 16 repeated images.

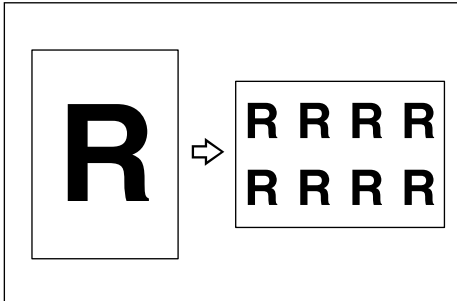

### Limitation

- Part of the repeated image might not be printed depending on the paper sizes, reproduction ratio and paper orientation.

### Note

- You can print a separation line in between the repeated images. See p.159 “Combine/Image Repeat Separation Line”.

Refer to the following tables when you select the original and paper sizes:

### ❖ Placing originals in the optional ADF (metric version)

Original	A3	B4 JIS	A4	B5 JIS	A5
A3	*2	*2	*3	*3	*4
B4 JIS	*1	*2	*2	*3	*3
A4	*1	*1	*2	*2	*3
B5 JIS	--	*1	*1	*2	*2











\*1: You can use these original and paper sizes to repeat 2 images.

\*2: You can use these original and paper sizes to repeat 2 or 4 images.

\*3: You can use these original and paper sizes to repeat 2, 4 or 8 images.

\*4: You can use these original and paper sizes to repeat 2, 4, 8 or 16 images.

**❖ Placing originals in the optional ADF (inch version)**

Original	11" × 17" 	8½" × 14" 	8½" × 11"  	8½" × 5½"  
Paper				
11" × 17" 	*2	*2	*3	*4
8½" × 14" 	*1	*2	*2	*3
8½" × 11"  	*1	*1	*2	*3
5½" × 8½" 	--	--	*1	*2

\*1: You can use these original and paper sizes to repeat 2 images.

\*2: You can use these original and paper sizes to repeat 2 or 4 images.

\*3: You can use these original and paper sizes to repeat 2, 4 or 8 images.

\*4: You can use these original and paper sizes to repeat 2, 4, 8 or 16 images.

**❖ Placing originals on the exposure glass (metric version)**









Original	A3 	B4 JIS 	A4  	B5 JIS  
Paper				
A3 	*2	*2	*3	*3
B4 JIS 	*1	*2	*2	*3
A4  	*1	*1	*2	*2
B5 JIS  	--	*1	*1	*2

\*1: You can use these original and paper sizes to repeat 2 images.

\*2: You can use these original and paper sizes to repeat 2 or 4 images.

\*3: You can use these original and paper sizes to repeat 2, 4 or 8 images.

**❖ Placing originals on the exposure glass (inch version)**

Original	11" × 17" 	8½" × 14" 	8½" × 11"  
Paper			
11" × 17" 	*2	*2	*3
8½" × 14" 	*1	*2	*2
8½" × 11"  	*1	*1	*2
5½" × 8½" 	--	--	*1

\*1: You can use these original and paper sizes to repeat 2 images.

\*2: You can use these original and paper sizes to repeat 2 or 4 images.

\*3: You can use these original and paper sizes to repeat 2, 4 or 8 images.

**1** Place the originals.

**2** Press [Edit Image].

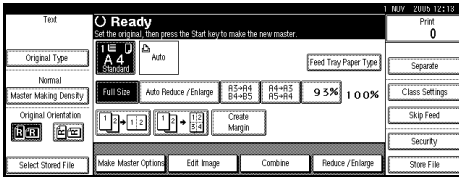

**3** Press [Edit Image].

**4** Press [Image Repeat].

**5** Select [2 Repeat], [4 Repeat], [8 Repeat], or [16 Repeat].

**6** Press [OK] three times.

**7** Press the [Start] key.

3

## Custom Repeat

Use this function to print repeated images from a small original, such as a memo or name card. Images are repeated as often as the paper size allows.

The sizes of originals you can use are as follows:

Metric version	Vertical: 50 – 300 mm Horizontal: 50 – 432 mm
Inch version	Vertical: 2.0 – 11.7 inch Horizontal: 2.0 – 18 inch

### Limitation

You cannot use Image Rotation, Size Magnification, or Erase Border with this function.

**1** Place the originals.

**2** Press [Edit Image].

**3** Press [Edit Image].

**4** Press [Image Repeat].

**5** Press [Custom Repeat].

**6** Enter the vertical size of the original using the number keys, and then press [#].

**7** Enter the horizontal size of the original using the number keys, and then press [#].

**8** Press [OK] four times.

**9** Press the [Start] key.

## Centring

You can make copies with the image moved to the centre.

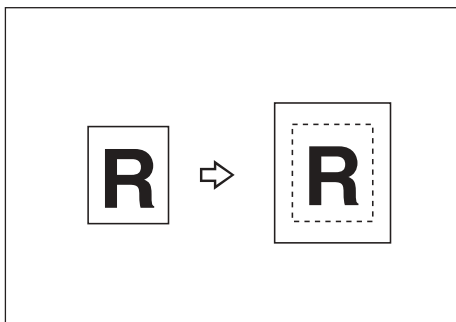

GCCNTR0E

### Note

- Original sizes and orientations for centring are listed below.

#### ❖ Metric version

Original placed on:	Original size and orientation
Exposure glass	A3☐, B4 JIS☐, A4☐☐, B5 JIS☐☐
ADF	A3☐, B4 JIS☐, A4☐☐, B5 JIS☐☐, A5☐☐

#### ❖ Inch version

Original placed on:	Original size and orientation
Exposure glass	11" × 17"☐, 8 <sup>1</sup> / <sub>2</sub> " × 14"☐, 8 <sup>1</sup> / <sub>2</sub> " × 11"☐☐
ADF	11" × 17"☐, 8 <sup>1</sup> / <sub>2</sub> " × 14"☐, 8 <sup>1</sup> / <sub>2</sub> " × 11"☐☐, 5 <sup>1</sup> / <sub>2</sub> " × 8 <sup>1</sup> / <sub>2</sub> "☐☐

**1** Place the originals.

**2** Select paper.

**3** Press [Edit Image].

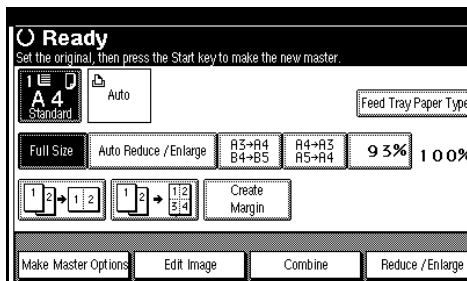

**4** Press [Edit Image].

**5** Press [Centring].

**6** Press [OK] twice.

**7** Press the [Start] key.

## Erase Border

This function erases all four margins of the original or paper. You can select the Erase Original Border mode or Erase Paper Border mode.

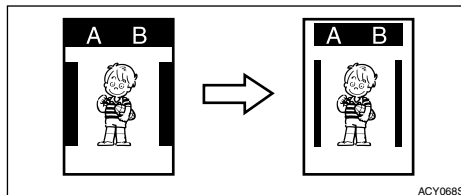

ACY068S

### Note

- You can adjust the size of the margins with User Tools. The default is 2 mm, 0.1". See p.160 "Erase Original Border Width" p.160 "Erase Paper Border Width".



## Erase Original Border

- 1** Place the originals.
- 2** Press [Edit Image].

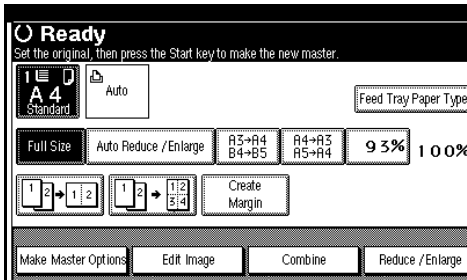

- 3** Press [Edit Image].
- 4** Press [Erase Border].
- 5** Press [Erase Original Border].
- 6** Select the size and direction of the original.
- 7** Press [OK] four times.
- 8** Press the [Start] key.

## Erase Paper Border

- 1** Place the originals.
- 2** Press [Edit Image].

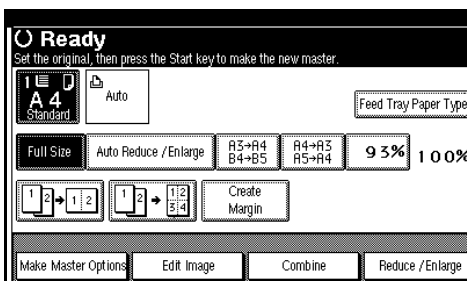

- 3** Press [Edit Image].
- 4** Press [Erase Border].
- 5** Press [Erase Paper Border].

- 6** Select the size and direction of the paper.

- 7** Press [OK] four times.

- 8** Press the [Start] key.

## Margin Adjustment

You can make a binding margin.

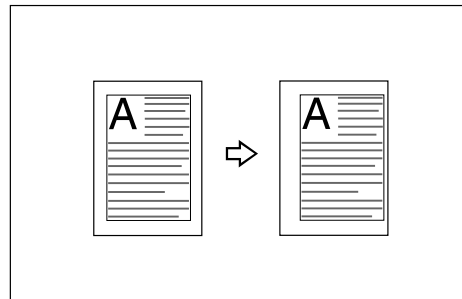

### Note

- You can change the width of the binding margin as follows:

Metric version	0–30 mm (increments of 1 mm)
Inch version	0"–1.2" (increments of 0.1")

- 1** Place the originals.

- 2** Press [Edit Image].

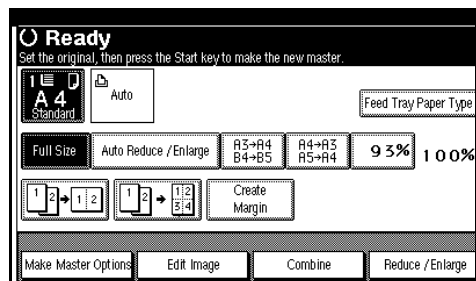

- 3** Press [Edit Image].

- 4** Press [Margin Adjust].

**5** Set a binding margin for the front pages. Press [←] and [→] when setting the left and right margins, and [↓] and [↑] when setting the top and bottom margins.

**Note**

- To change the value entered, press [←], [→], [↓], [↑] to set it.

**6** Press [OK] three times.

**7** Press the [Start] key.

## Overlay

The machine can merge two different originals onto a single sheet.

Three types of merging are available:

❖ **Image Overlay**

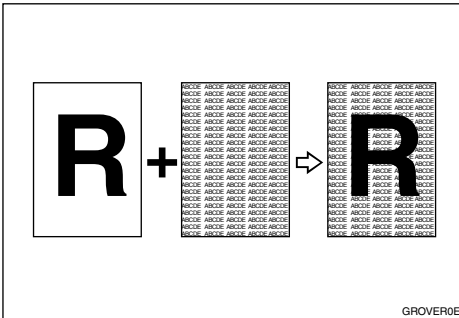

Two different originals are merged onto a single sheet.

**Note**

- You can select the background image from online data, scanned data or stored file.

❖ **Format Overlay (Scan + Scan)**

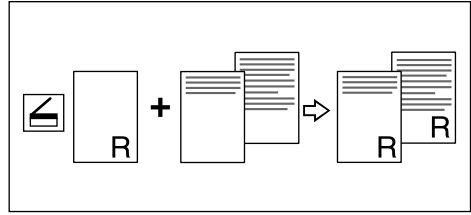

The image of the original scanned first becomes the background image for all subsequent prints.

❖ **Format Overlay (Stored + Stored)**

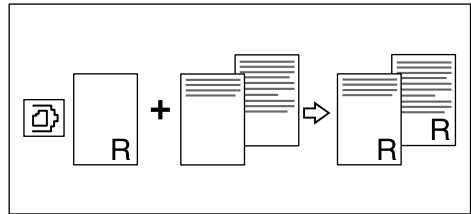

The image of the original selected from stored files first becomes the background image for all subsequent prints. The following originals selected from stored files are printed with this background.

**Note**

- When using stored files to make overlay images, check if the orientation of stored files is appropriate.

## Image Overlay

- 1** Place the original.
- 2** Press [Edit Image].

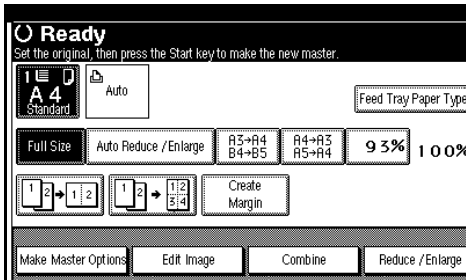

- 3** Press [Overlay].
- 4** Press [Image Overlay].
- 5** Select the original overlay 1 type.  
You can select the online data, scanner or stored file.

### Select online data

- 1** Press [Online Data].
- 2** Start printing with your computer.

### Select scanner

- 1** Press [Scanner].
- 2** Place the original, and then press the [Start] key.

### Select stored file

#### Note

- This function can be used only when the optional HDD board is installed.

- 1** Press [Stored File].
- 2** Press the stored file name you want to select, and then press [OK].
- 3** Press the [Start] key.

## Format Overlay (Scan + Scan)

- 1** Place the first original.
- 2** Press [Edit Image].

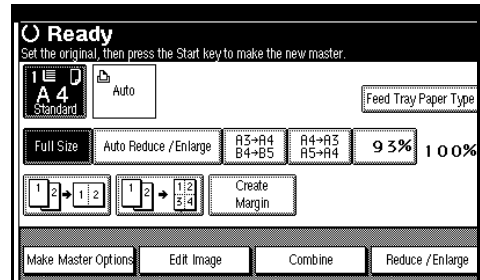

- 3** Press [Overlay].
- 4** Press [Format Overlay (Scan + Scan)], and then press [OK].
- 5** Press the [Start] key.  
Master making starts.
- 6** Place the second original, and then press the [Start] key.

## Format Overlay (Store + Store)

#### Note

- This function can be used only when the optional HDD board is installed.

- 1** Press the [Master Making] mode select key.
- 2** Press [Edit Image].

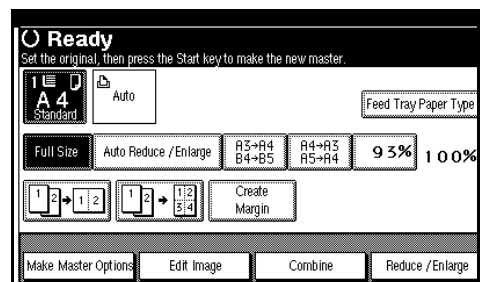

- 3** Press [Overlay].
- 4** Press [Format Overlay (Store + Store)].

- 5 Press [Stored File (Page1)].
- 6 Press the stored file name you want to select as an original format, and then press [OK].
- 7 Press [Stored File].
- 8 Press the stored file name you want to select as an overlay original, and then press [OK].
- 9 Press the [Start] key.

## Preset Stamp

One of the following three messages can be stamped on prints with a frame around it:

CONFIDENTIAL

PRIORITY

PRELIMINARY

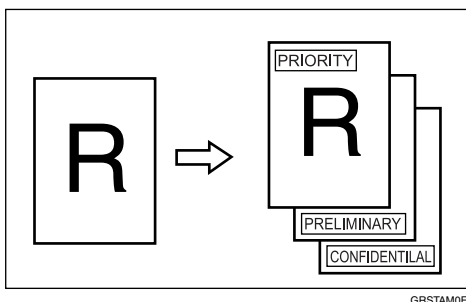

GRSTAMP0E

### Limitation

- Only one message can be stamped at a time.

### Note

- This function can be used only when the optional HDD board is installed.
- The message "CONFIDENTIAL" is selected as a default. You can change this setting with User Tools. See p.160 "Stamp Type Defaults".

## Stamp position and original orientation

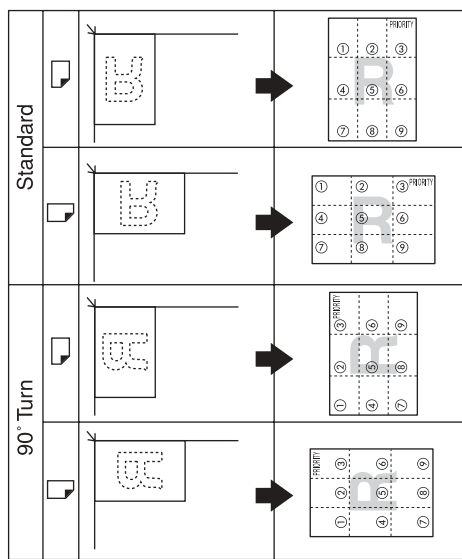

Key on the display	↶	↑	↗	↵	*	→	↙	↓	↘
Stamp position	①	②	③	④	⑤	⑥	⑦	⑧	⑨

GCSTMP5E

- 1 Place the originals.
- 2 Press [Edit Image].

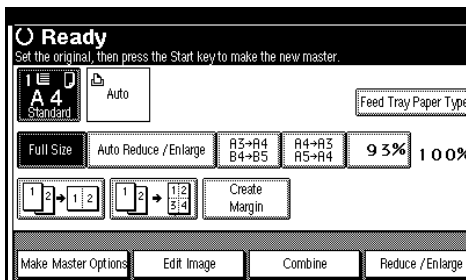

- 3 Press [Preset Stamp].
- 4 Select the message.
- 5 Press [All Pages] or [1st Page Only] to select the print page.

### Note

- You can change the stamp position, size, and density of the stamp. See p.81 "To change the stamp position, size, and density".

- 6** After you have specified all necessary settings, press [OK].
- 7** Press [OK] twice.
- 8** Press the [Start] key.

---

To change the stamp position, size, and density

---

- 1** Press [Change].
- 2** Select the position for print, size, and density, and then press [OK].







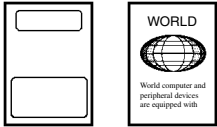

## Make-Up Printing Features

Make-Up mode enables you to do more than just make an exact print of the original. A variety of editing and image processing functions allow you to quickly and easily customize your prints.

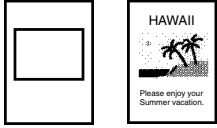

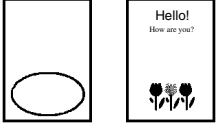

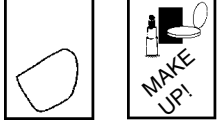

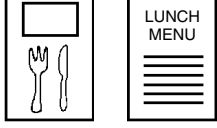
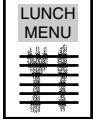
### Main Features

Command sheet allows you to create special effects without cutting and pasting. By combining Make-Up modes and printing with different colour drums, you can create a variety of printing effects.

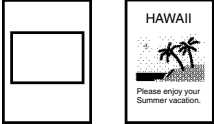
### Make-Up Modes for Inside Areas

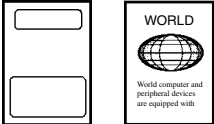
Mode		Sample	
		Command sheet/Original (Closed area method)	Print
1.	Text mode		
2.	Photo mode		
3.	Erase mode		
4.	Centre Erase mode		
5.	All Area mode		

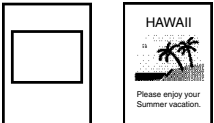
## Make-Up Modes for Outside Areas

Mode		Sample	
		Command sheet/Original	Print
1.	Text mode: The area outside designated areas is printed in Letter mode.		
2.	Photo mode: The area outside designated areas is printed in Photo mode.		
3.	Erase mode: The area outside the designated areas is deleted.		

 **Note**

- In Make-Up mode, commands must be given for both inside areas and outside areas.

## Background Patterns

A total of 160 background patterns is available in Make-Up mode:

- 40 basic patterns
- 40 patterns similar to the basic patterns but with patterns elements at 4 times the size.
- 80 variants based on 90° rotations of all the basic and enlarged patterns.

3

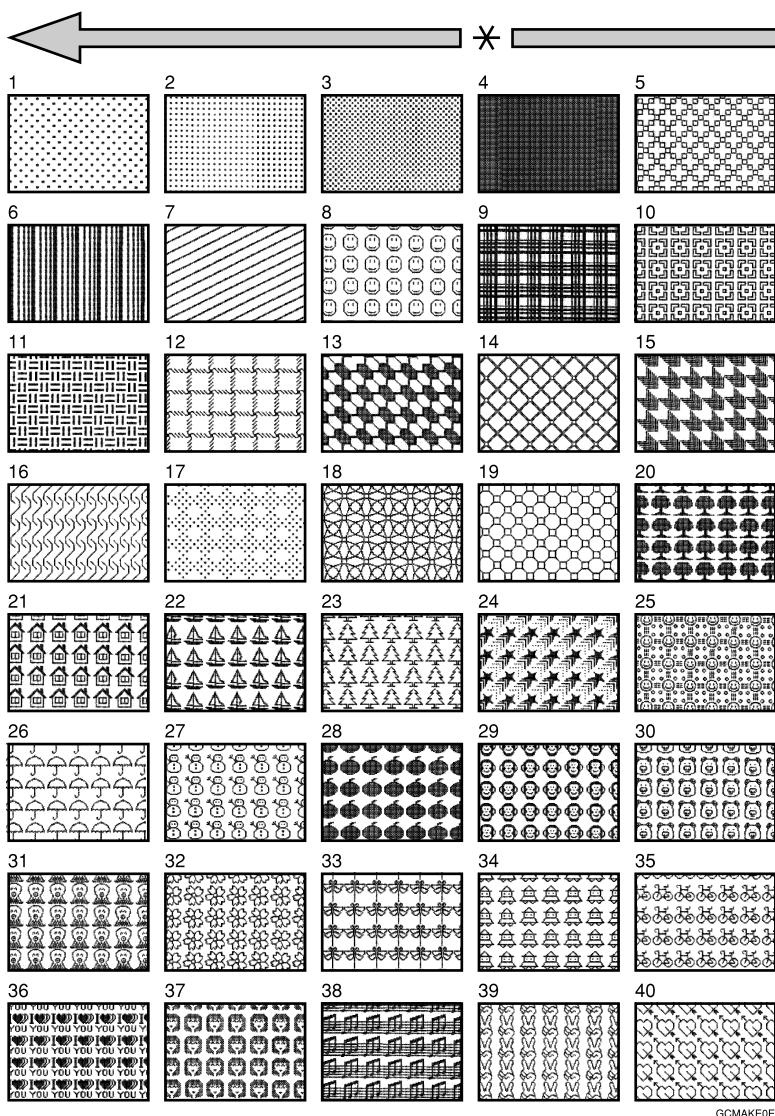

GOMAKE0E

\* Paper Feed Direction

**Note**

The basic patterns are numbered 1 to 40.



---

## Command Sheets for Make-Up Printing

---

Command sheets are fed first so that the machine can recognize the areas of the original which are to be edited as designated areas.

---

### Command Sheets

---

The command sheet is a sheet of paper designating the areas to be edited. Command sheets must be made on white or translucent paper, and should be the same size as the original.

Do not designate areas within 5 mm, 0.2" from the top.

 **Note**

- Poor quality paper (such as newsprint, recycled paper, etc.) should not be used for command sheets because any dark spots or streaks will be read as designated areas.
- Do not use blotting paper or other absorbent paper for command sheets because ink might leak through the paper and get the exposure glass dirty.

## Making a Command Sheet

There are two ways of designating areas: the closed area method and the diagonal line method.

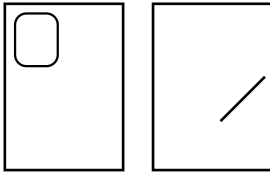

3



### Features

- You cannot use both the closed and diagonal line method on the same command sheet.

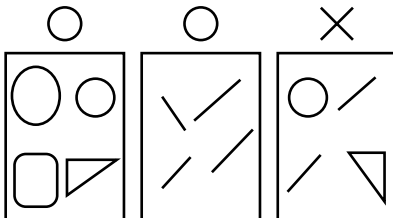



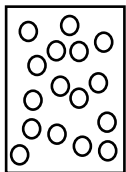

- There is no limit to the number of areas you can designate on a single command sheet.

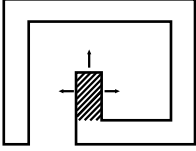

- If you use Outline mode for letter images with a thickness of less than 3mm, 0.12", the print image might come out as expected.

 **Notes**

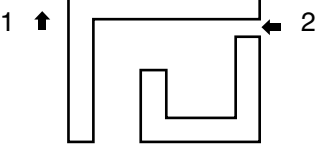
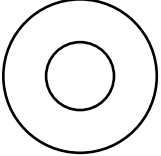
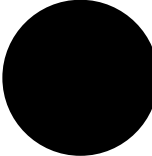
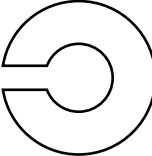
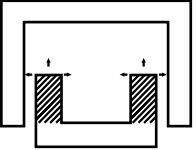
The image might differ depending on how the designated area is drawn, so remember the following when making the command sheet.

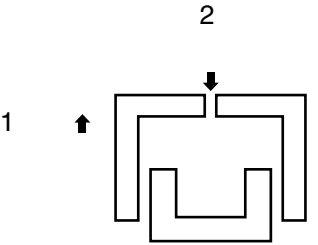
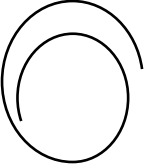
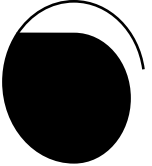
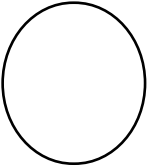
Designated area	Area recognized	Preferred designated area
<p>Part of the designated area is surrounded by 3 sides of the entire area.</p> 		<p>Make a space of at least 2mm, 0.08", in front of the area surrounded by 3 sides (relative to the feed direction).</p>  <p>1, 2 = 2mm, 0.08"</p>
<p>Double line pattern.</p> 	<p>Only the outer line is recognized.</p> 	<p>Make a gap of at least 2mm, 0.08" in width.</p> 
<p>The designated area is surrounded by 3 sides of another designated area.</p> 		<p>Make a space of at least 2mm, 0.08" in front of the area surrounded by 3 sides (relative to the feeding direction).</p>  <p>1, 2 = 2mm, 0.08"</p>
<p>Non-closed line</p> 		<p>Designate the area with a closed line.</p> 

## Diagonal line method

### Note

- A diagonal line must be drawn through the area that you wish to edit.

### **1** Put the command sheet on top of the original.

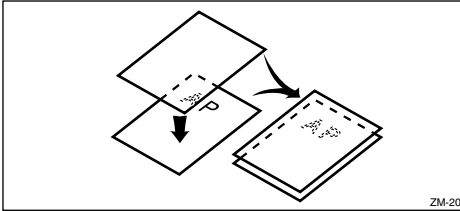

### **2** Draw a line using a felt tip pen (black, red or blue) with a thickness of at least 1mm.

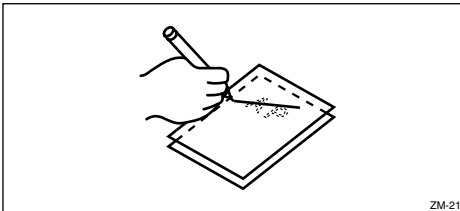

### Note

- Make sure there is no break in the line.
- The diagonal line can be drawn from left to right or vice versa.
- Draw the line at least 2mm, 0.08", away from the image so that the whole image can be recognized.

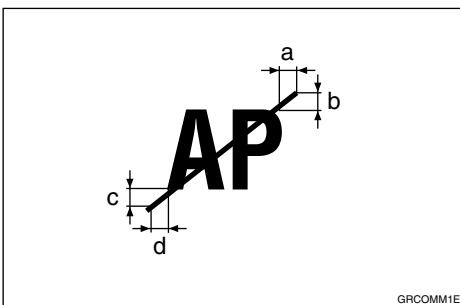

$a, b, c, d = 2\text{mm}, 0.08''$

- The line marking the designated area should be more than 2mm, 0.08", from any neighboring image.

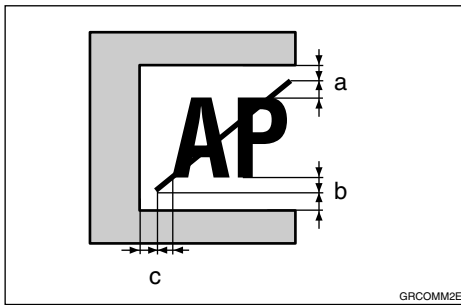

$a, b, c = 2\text{mm}, 0.08''$

### Closed area method

 **Note**

- The line designating the area must be a closed loop.

**1** Put the command sheet on top of the original.

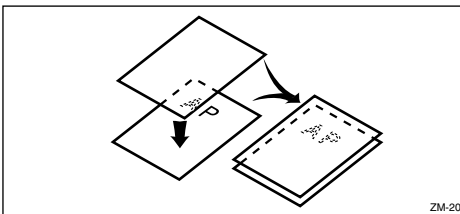

**2** Using a black, red, or blue felt tip pen, draw a line around the area to designate. The line should have a thickness of at least 1mm.

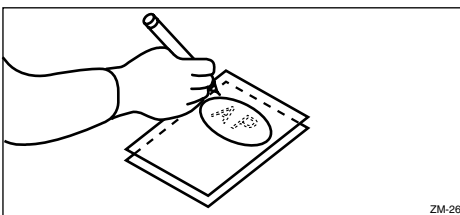

 **Note**

- Make sure there is no break in the line.
- Draw the line at least 2mm, 0.08", away from the image so that the whole image can be recognized.

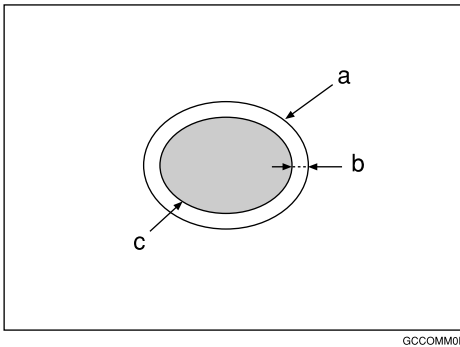

GCCOMM0E

a = Line marking the designated area

b = 2mm, 0.08"

c = Image within the designated area

- The line marking the designated area should be more than 2mm, 0.08", from any neighboring image.

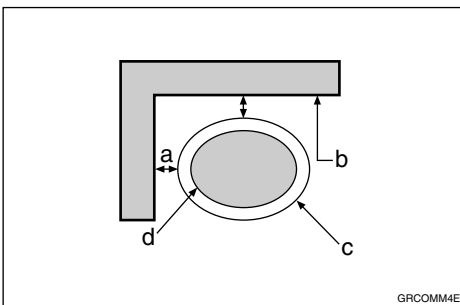

GRCOMM4E

a = 2mm, 0.08"

b = Neighboring image

c = Line marking the designated area

d = Image within the designated area

## Command Sheets and Finished Prints

The following illustrations will help you understand how to draw a command sheet.

### ❖ Drawing a command sheet using a diagonal line

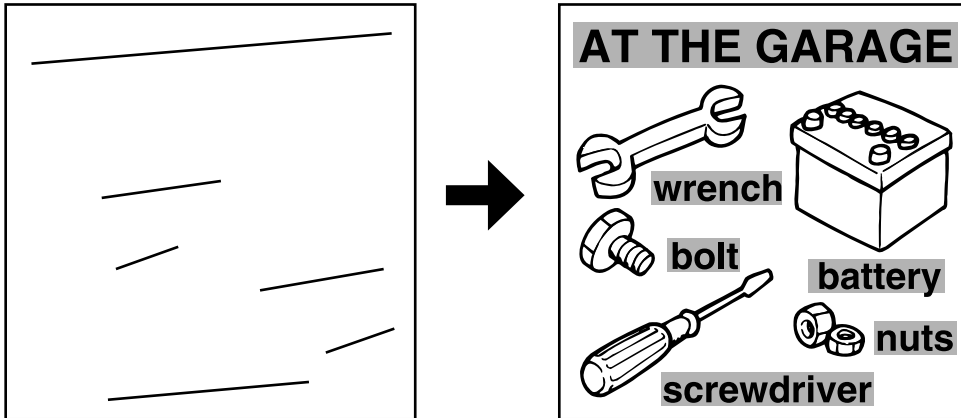

The diagonal line method is easy to use for designating rectangular areas. It is also more precise, but it is difficult to use for designating complex areas.

### ❖ Drawing a command sheet using a closed line

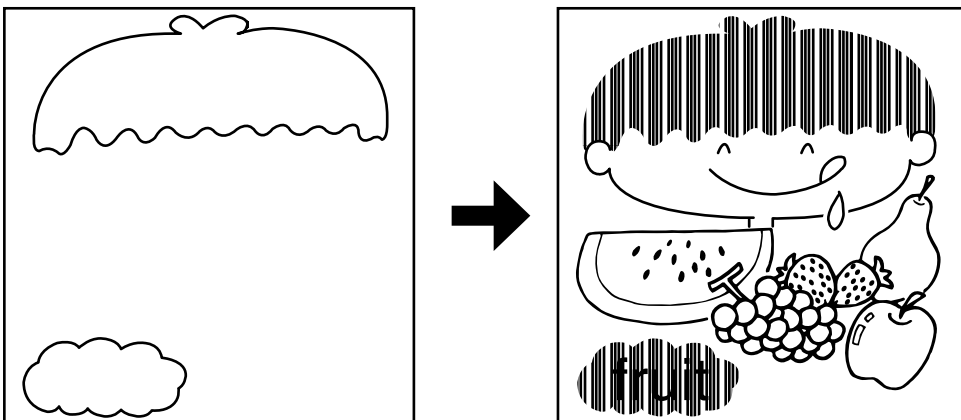

The closed line method is easier to use for complex areas, but it is less precise. It also takes longer to draw a command sheet with the closed line method.

## Make-Up Printing

- 1 Place the command sheet face down on the exposure glass.

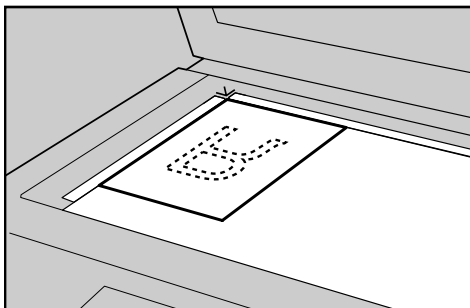

ZDCH110E

- 2 Press [Edit Image].

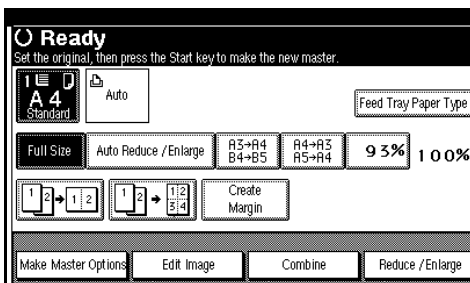

- 3 Press [Make-Up].
- 4 Select Area Select Method.
- 5 Press [Edit Method].
- 6 Select the mode of inside area and outside area.

When you select the Photo mode

- 1 Select the contrast and screen type, and then press [OK].
- 7 Press the [OK] key.

### Note

- When you select Photo mode for both inside and outside areas, you cannot select different dot patterns and contrast.
- When you want to confirm your settings, press [Make-Up].

- 8 Press the [Start] key.

- 9 Place the originals face down on the exposure glass or face up into the ADF, and then press the [Start] key.

### ❖ Exposure glass

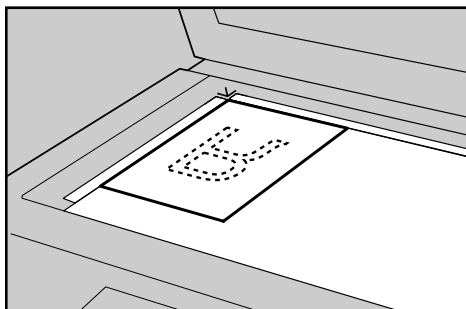

ZDCH110E

### ❖ ADF

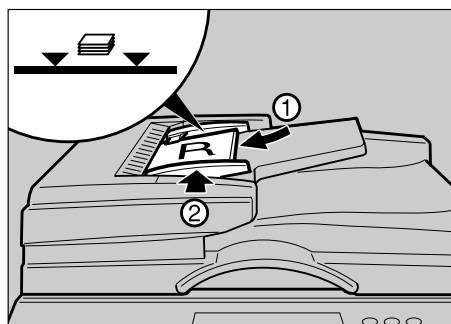

AJK153S

### Note

- If a command sheet or original misfeeds from the ADF, remove the misfed sheet or original and reset it in the ADF.
- It is not necessary to reset the previous command sheets or original.



**Printing Samples**

**Sample 1**

- ① Command Sheet, Frame shape, Inside area: Erase Area mode
- ② Outside area: Text mode
- ③ Print

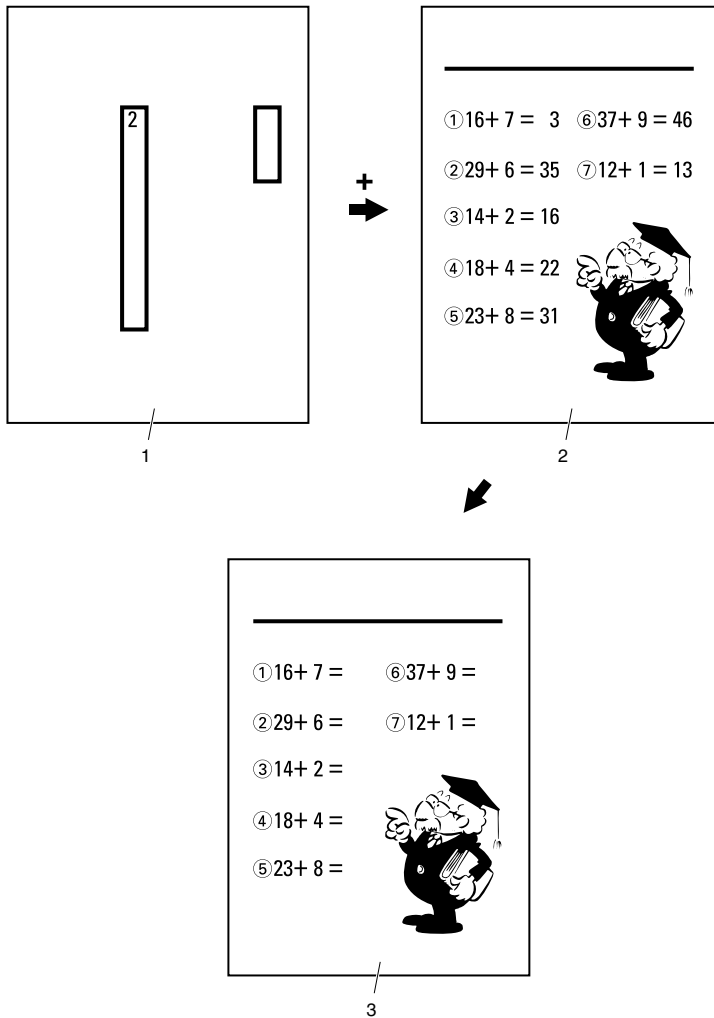

- 1. Command sheet**
- 2. Original**
- 3. Print**

ZM-50

 **Sample 2**

- ① Print the original as it is
- ② Change the drum unit for colour printing
- ③ Command Sheet, Frame shape, Inside area: All Area pattern No. 39
- ④ Outside area: Text mode
- ⑤ Print

3

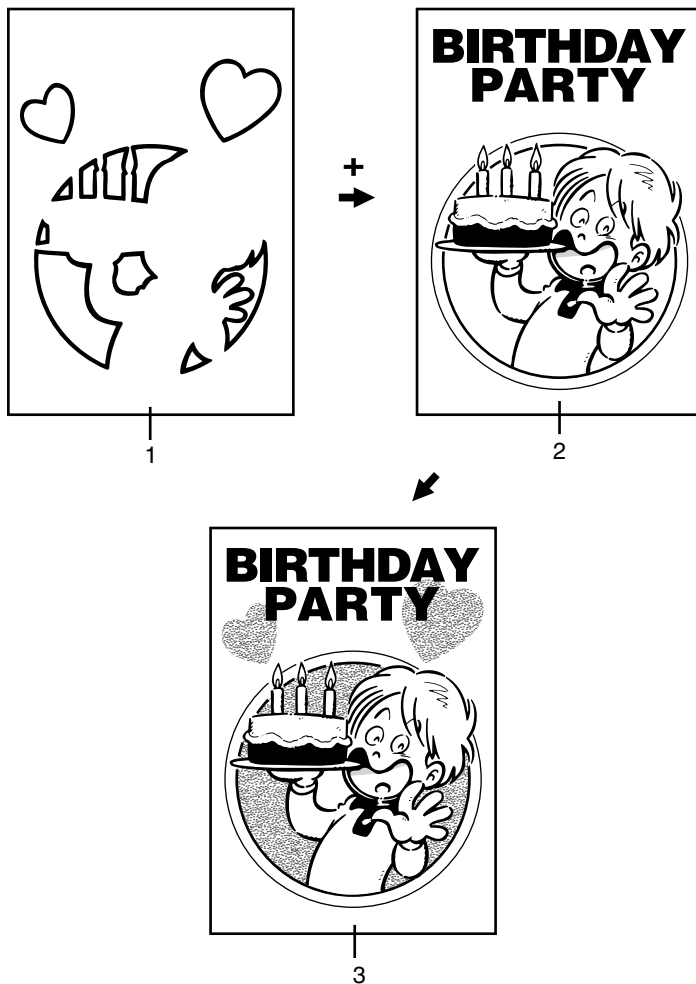

ZM-52

- 1. Command sheet
- 2. Original
- 3. Print

## Quality Start

If the machine is not used for a long time, or when you change to a colour drum unit that has not been used recently, the ink on the drum may dry up. This might affect the print quality. To solve this problem, you can have the machine carry out a few idle spins of the drum before a print run.

### Note

- You can change the number of spins in Quality Start mode with User Tools. See p.155 “No.of Idling Rotations: Quality Start”.

**1** Place the originals.

**2** Press [Make Master Options].

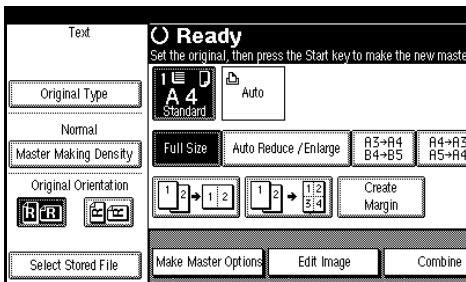

**3** Press [Quality Start], and then press [OK].

**4** Press the [Start] key.

The drum unit idles.

## Auto Quality Start

You can program the machine to automatically carry out a few idle spins before a print run. This is called Auto Quality Start.

### Note

- To use this function, you need to set Auto Quality Start to [On] using User Tools. See p.154 “Auto Quality Start Setting”.
- To specify the number of idle spins according to the length of time for which the machine is not used, see p.154 “No.of Idling Rotations: Auto Quality Start”.

## Economy Mode

When you want to save ink, select economy mode.

### Note

- Prints will be lighter in this mode.
- You can select the two kind of economy mode , level 1 and level 2.
- Level 2 will be lighter than level 1.

**1** Place the originals.

**2** Press [Make Master Options].

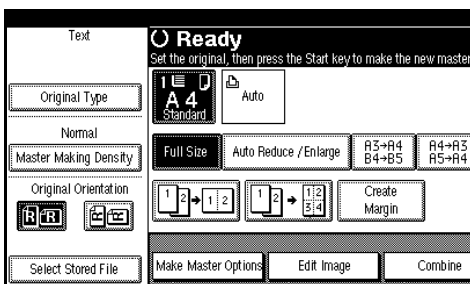

**3** Press [Eco. Mode: Level 1] or [Eco. Mode: Level 2].

**4** Press the [Start] key.

## Skip Feed

If the backs of prints are dirty, you can use the Skip Feed function to make the drum rotate twice instead of once with every sheet of paper fed. This gives you time to remove prints one by one from the paper delivery tray or to insert a sheet of paper between two prints.

### Preparation

The number of rotations can be set from 2 to 9. The default is 2. To change this setting, see p.154 "Skip Feed".

### Note

- As the paper feeding time is longer than usual, you can use paper longer than the length limitation. The maximum length of paper in Skip Feed mode is 460 mm, 18.1".
- When you use paper longer than 432 mm, 17.0", prints will not be delivered to the paper delivery tray properly, so lower the paper delivery end plate and take out the prints by hand.

**1** Place the originals.

**2** Press [Skip Feed].

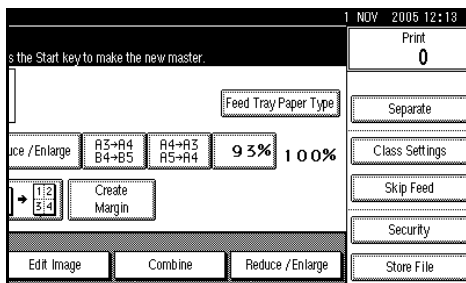

To change the number of drum rotations

In this step, you can change the number of rotations temporarily. You can also have this step omitted by adjusting the User Tools settings. See p.154 "Skip Feed".

**1** Select the number of drum rotations per sheet of paper fed with number keys.

### Note

- After printing is completed, the Skip Feed setting returns to the default.

**2** Press [OK].

**3** Press the [Start] key.

## Security

When printing confidential documents such as examination papers, use this function to prevent others from using the master.

If you select Higher Security in the Security Option setting, the master eject unit will be locked and cannot be taken out.

### Preparation

This function has two security options. Select which option to use in User Tools before using this function. See p.157 "Security Option".

- Normal: No additional prints can be made and the drum unit cannot be pulled out.
- Higher Security: No additional prints can be made. The drum unit and the master eject unit cannot be pulled out.

### Note

- ❑ The selected security mode cannot be cleared by turning off the main switch.

## Setting "Normal" Security

- 1 After making prints, press [Security].

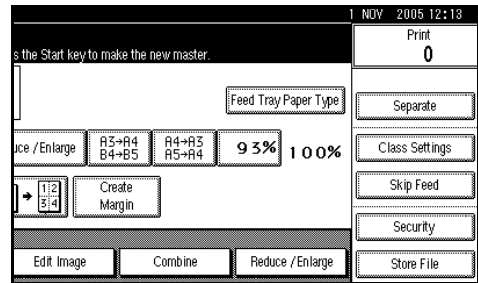

A confirmation dialog box will appear.

- 2 Press [OK].

The master is protected by the security function.

## Disabling "Normal" Security

- 1 Place a new original, and then press the [Start] key.

The security function is canceled.

## Setting "Higher" Security

- 1 Select "Higher Security" in "Security Option" with the User Tools. See p.157 "Security Option".

- 2 Register a security code.

## Disabling “Higher” Security

**1** Press [Security].

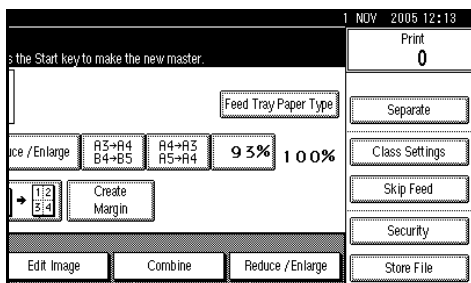

**2** Enter the security code using the number keys, and then press [OK].

The lock is canceled. You can pull out the master unit and drum unit.

### Note

Under this option, security can only be disabled temporarily and resumes automatically when following occurs:

- the present print job finishes
- you return the master eject unit to its original position after pulling it out
- you close the front door after pulling out the drum unit and returning it to its original position
- a certain period passes, during which neither the master eject unit nor the drum unit was pulled out, following security function cancellation
- you press the **[Start]** key
- the machine enters the Energy Saver or Auto Off mode
- the machine enters the Auto Reset mode

## Setting Security Timer

You can set the time that shifts to the security mode automatically. See p.157 “Security Timer”.

## Conserving the Master

The machine automatically changes the master length depending on the paper size you use. This saves both master and ink.

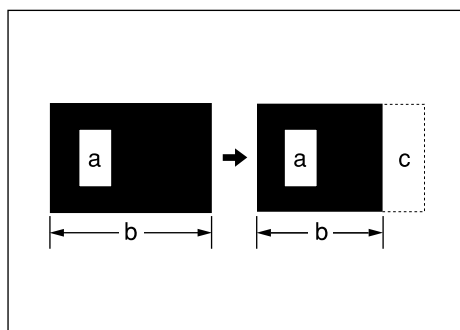

a = Images on the master

b = Masters

c = Conserved area

### Limitation

This function is automatically turned on when you place two or more originals in the optional ADF.

The paper sizes you can use are A4  $\square$ ,  $8\frac{1}{2}'' \times 11''$   $\square$  or B5 JIS  $\square$ .

You can cancel Master Saving mode with User Tools. See p.156 “Master Cut Length”. You can also save master using the optional A4 drum. See p.113 “Changing the Drum Size”.

- When you select **[A3]** in Master Length, the masters are cut into A3 size.
- When you select **[Auto]** in Master Length, the masters are cut into A4  $\square$  size. Only the last page is cut into A3  $\square$  size.

## Double Feed

When two or more sheets of paper feed at once, the machine stops and a warning message appears on the display.

### Preparation

To use the Double Feed function, select **[On]** in “Double Feed Warning” with User Tools. See p.156 “Double Feed Warning”.

### Note

- Double Feed function may not detect the paper properly when:
  - there is a mixture of different coloured paper
  - there is a mixture of paper of differing thickness
- Double feed is possible with paper size from A6 to A3, 11" × 17".

## When a Double Feed is Detected

When a double feed is detected, the machine stops and a warning message appears on the display.

### **1** Check the output and press **[Exit]**.

#### Note

- When the misfeeds message is displayed, remove the misfed paper. See p.130 “ Clearing Misfeeds”.
- When paper is wrapped around the drum, open the front door and remove it. See p.132 “When the master is wrapped around the drum”.

### **2** Remove the misfed paper.

#### Note

- If a double feed is wrongly detected while printing on the reverse side of paper or the face of printed paper, select **[Off]** for “Double Feed Warning” with User Tools. See p.156 “Double Feed Warning”.
- To prevent double feed, see p.165 “Do's and Don'ts”.

# Storing File

## Storing Data

### Note

- ❑ This function can be used only when the optional HDD board is installed.

### ❖ File Name

Stored files will automatically be named as "COPY0001", "COPY0002". You can change assigned file names.

### ❖ User Name

You can register a user name to distinguish the user that stored the files.

### ❖ Password

You can set a password for stored files, and use it to prevent others printing them.

### ⚠ Important

- ❑ Data stored in the machine might be lost if some kind of failure occurs. The supplier shall not be responsible for any damage that might result from the loss of data.
- ❑ Be careful not to let anyone know your password, especially when entering a password or recording it. Keep any record of your password in a secure place.
- ❑ Avoid using a single number or consecutive numbers for a password such as "0000" or "1234", since the numbers like this are easy to guess, so using them will not provide a worthwhile level of security.
- ❑ A file accessed with a correct password remains selected even after operations are complete, and it can be accessed by other users. To stop this, be sure to press the **[Clear Modes]** key to cancel the file selection.

- ❑ The user name used when adding a file to the machine is to identify the file creator and type. It is not to protect confidential files from others.

### Note

- ❑ Enter a four-digit password.
- ❑ You can access to the files without entering a password temporarily. See p.157 "Temporarily Unlock Stored Files"
- ❑ You can specify the time taken for the stored data to be deleted automatically. See p.157 "Auto Delete File".
- ❑ If you do not want stored data to be automatically deleted, select **[No]** in Auto Delete File before storing a file. If you select **[Yes]** later, data stored afterward will be automatically deleted.
- ❑ When storing files sent from computers, the orientation may be changed depending on the paper orientation on the paper feed tray.

## 1 Place the originals.

### 🔍 Reference

For details on the types of originals and how to place them, see p.42 "Placing Originals".

## 2 Press [Store File].

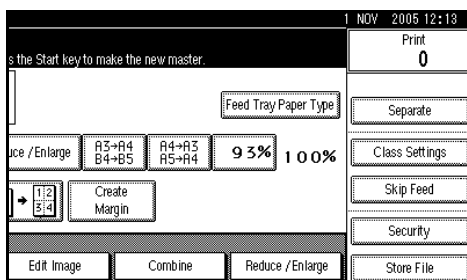



**3** Enter a user name, file name, or password if necessary.

**Note**

- ❑ If you do not enter a file name, one will be automatically assigned.

**Reference**

- p.101 "To register a user name"
- p.101 "To change a file name"
- p.102 "To set or change a password"

**4** Press [OK].

**5** Make settings as desired.

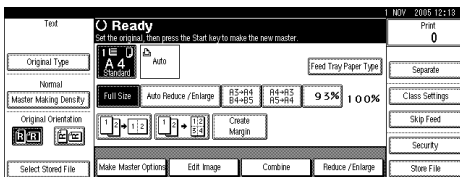

**Reference**

For details, see p.57 "Printing Functions"

**6** Press the [Start] key.

The file is stored in the machine.

**Note**

- ❑ To stop scanning, press the [Clear/Stop] key. To resume a paused scanning job, press [Continue] in the confirmation dialog box. To delete stored images and cancel the job, press [Stop].
- ❑ When using the exposure glass, after the first original is scanned, place the subsequent one on the exposure glass, and then press the [Start] key again. After all the originals are scanned, press the [#]key.

**To register a user name**

**1** Press [Store File].

**2** Press [User Name].

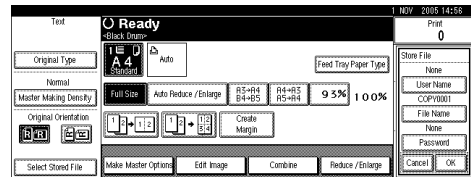

The User Name display appears.

**3** Enter a user name, and then press [OK].

**Reference**

p.175 "Entering Text"

**Note**

- ❑ Up to 20 characters can be entered as a file name, but only 16 characters of each file name will be displayed in the file list.

**To change a file name**

**1** Press [Store File].

**2** Press [File Name].

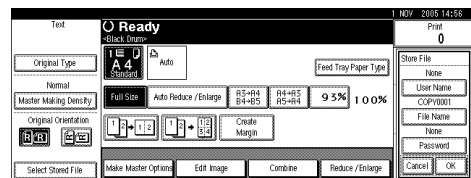

The File Name display appears.

- Press [Delete All] to delete the old file name.



**Note**

- You can also use [Backspace] to delete unwanted characters.

- Enter a new file name, and then press [OK].

**Reference**

p.175 "Entering Text"

**Note**

- Up to 20 characters can be entered as a file name, but only 16 characters of each file name will be displayed in the file list.

**To set or change a password**

- Press [Store File].
- Press [Password].

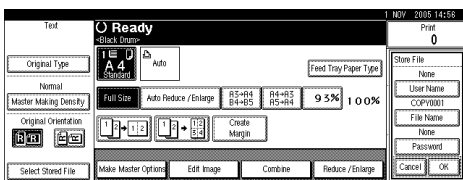

- Enter the password (four-digits) using the number keys, and then press [#].

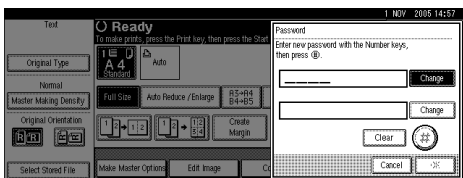

- Reenter the password (four-digits) for verification, and then press [#].

- Press [OK].

**Changing a Stored File's User Name, File Name, or Password**

- Press [Select Stored File].

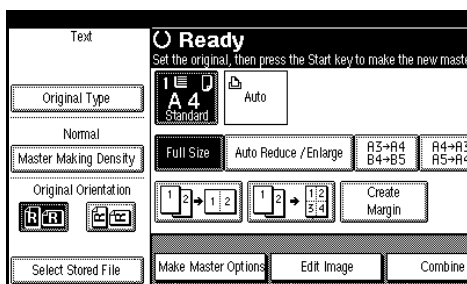

- Select the file with the user name, file name, or password you want to change.

**Note**

- If a password has been set for the file, enter the password and press [OK].

- Press [File Management].

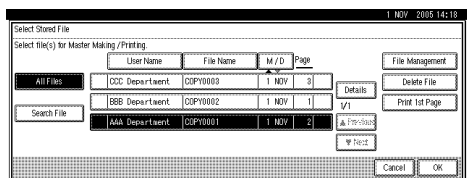

- Press [Change User], [Change File], or [Change Password].

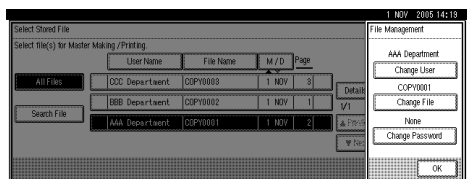

**5** Enter the new user name, file name, or password, and then press [OK].

**Reference**

- p.101 “To register a user name”
- p.101 “To change a file name”
- p.102 “To set or change a password”

**6** Press [OK].

## Searching for Stored Files

You can search for stored files in the machine. You can also list stored files in your order of preference.

**1** Press [Select Stored File].

**2** Press [Search File].

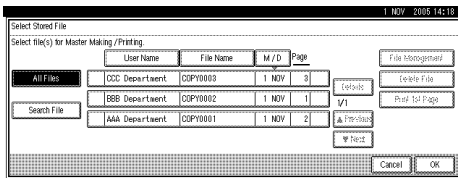

**3** Enter the file name, and then press [OK].

Files beginning with the name entered appear.

**Reference**

- p.175 “Entering Text”

**Note**

- To display all files stored in the machine, press [All Files].

## To Check Details of Stored Files

**1** Press [Select Stored File].

**2** Select the file.

**Note**

- If a password has been set for the file, enter the password, and then press [OK].

**3** Press [Details].

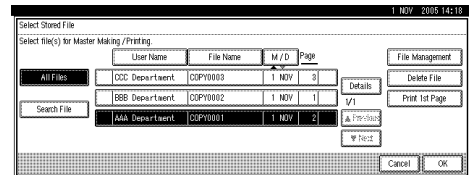

Detailed information about the file is displayed.

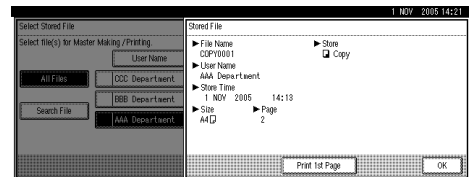

## Printing Stored Files

### Note

- You can also print stored files via a Web browser from a computer in the network. For details on how to start the Web browser, see *Network Guide*.

- Press **[Select Stored File]**.
- Select the file to be printed, and then press **[OK]**.

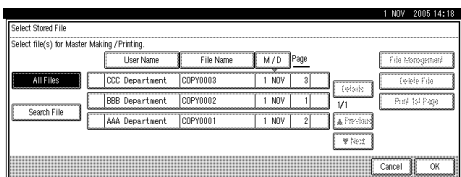

### Note

- If a password has been set for the file, enter the password and then press **[OK]**.
- You can search for a file using **[Search File]**.
- You can sort file names in the list by user name, file name or date. To sort files, press **[User Name]**, **[File Name]** or **[M / D]**.
- If you cannot determine the contents of a file by its file name, you can print only the first page of the file for checking purposes. See p.104 "Printing the First Page".
- To cancel a selection, press the highlighted file name again.

- Make settings as desired.

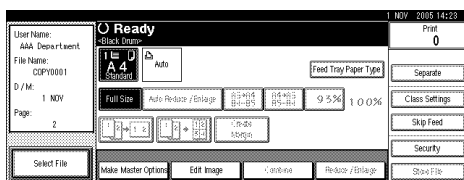

- Enter the required number of prints using the number keys.

### Note

- Up to 9999 can be entered.

- Press the **[Start]** key.

## Printing the First Page

You can print the first page of a file selected to check its contents.

- Press **[Select Stored File]**.

- Select the file.

### Note

- If a password has been set for the file, enter the password and then press **[OK]**.
- You can search for a file using **[Search File]**.
- You can sort file names in the list by user name, file name or date. To sort files, press **[User Name]**, **[File Name]** or **[M / D]**.
- If you cannot determine the contents of a file by its file name, you can print only the first page of the file for checking purposes.
- To cancel a selection, press the highlighted file name again.

- Press **[Print 1st Page]**.

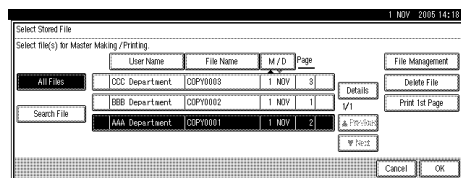

- Press the **[Start]** key.

## Deleting Stored Files

### Important

- ❑ You can store up to 3,000 files in the machine. No more files can be stored when the limit is reached, and you should delete unnecessary files.

### Note

- ❑ You can delete all stored files at once with User Tools. See p.157 “Delete All Files”.
- ❑ You can also delete stored files via a Web browser from a computer in the network. For details on how to start the Web browser, see *Network Guide*.

**1** Press **[Select Stored File]**.

**2** Select the file to be deleted.

### Note

- ❑ If a password has been set for the file, enter the password and then press **[OK]**.
- ❑ You can search for a file using **[Search File]**.
- ❑ You can sort file names in the list by user name, file name or date. To sort files, press **[User Name]**, **[File Name]** or **[M / D]**.
- ❑ If you cannot determine the contents of a file by its file name, you can print only the first page of the file for checking purposes.
- ❑ To cancel a selection, press the highlighted file name again.

**3** Press **[Delete File]**.

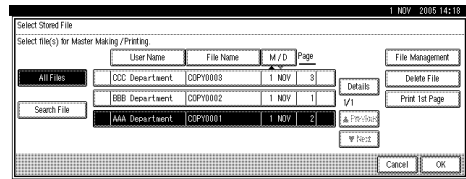

A confirmation dialog box will appear.

**4** Press **[Delete]** to delete the file.

## Printing or Deleting Stored Files Using a Web Browser

You can also print or delete the stored files using a web browser. For details, see the web browser's help.

# Programs

You can store frequently used print job settings in machine memory and recall them for future use.

 **Note**

- You can store up to 10 programs.
- You can select the standard mode or Program No.10 as the default mode to be set when modes are cleared or reset, or immediately after the operation switch is turned on.
- Programs are not deleted by turning the power off or pressing the **[Clear Modes]** key. They are canceled only when you delete or overwrite them with another program.

## Storing a Program

**1** Edit the print settings so all functions you want to store in this program are selected.

**2** Press the **[Program]** key.

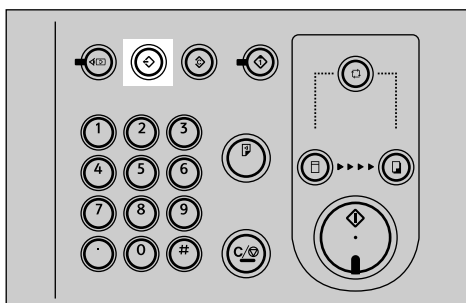

AJK131S

**3** Press **[Program]**.

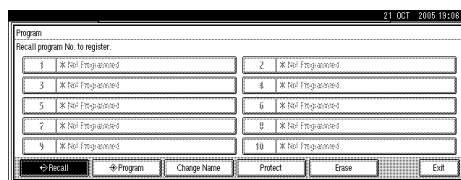

 **Note**

- Program numbers displayed with  next to them already have settings.

**4** Press the program number you want to store.

**5** Enter the program name using the letter keys on the display panel.

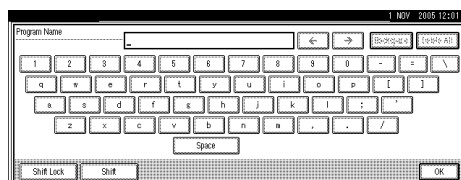

You can enter up to 40 characters.

 **Reference**

For details about entering characters, see p.175 "Entering Text".



 **Note**

- If you do not want to enter a program name, proceed to step **6**.

**6** Press **[OK]**.

When the settings are successfully stored, the  indicator followed by the program number and program name will be displayed.

## Recalling a Program

- 1** Place the originals.
  - 2** Press the [Program] key.  
The stored settings are displayed.
-  **Note**
- Program numbers displayed with  next to them already have settings.
- 3** Press the number of the program you want to recall.

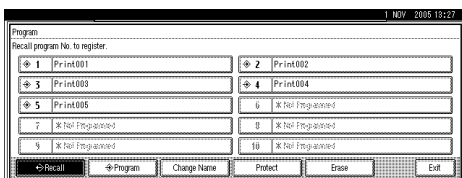

- 4** Press the [Start] key.

## Changing a Stored Program



- 1** Edit the print settings so all functions you want to store in this program are selected.
- 2** Press the [Program] key.
- 3** Press [Program].
- 4** Press the program number you want to change.  
A confirmation dialog box will appear.
- 5** Press [Yes].  
Repeat steps **5** and **6** of “Storing a program”.

## Changing a Program Name

- 1** Press the [Program] key.
- 2** Press [Change Name].
- 3** Press the program number you want to change the name.
- 4** Enter the new program name using the letter keys on the display panel.
- 5** Press [OK].

## Protecting a Program

If you want to prevent someone from writing over your program, do the following.

-  **Note**
- If all the user programs have been protected, you cannot store any setting in program menu.
- 1** Press the [Program] key.
  - 2** Press [Protect].
  - 3** Press the number of the program you want to protect.
-  **Note**
- Already protected program number are shown in highlight.

## Deleting a Program

---

- 1** Press the [Program] key.
- 2** Press [Erase].
- 3** Press the number of the program you want to delete.

A confirmation dialog box will appear.

- 4** Press [Delete].

The program is deleted, and the screen returns to the initial display.

3



# Making Colour Prints

Colour drum units are available as options in addition to the standard black unit. For making colour prints, a separate drum unit is necessary for each colour.

## Changing the Colour Drum Unit

- 1** Open the front door.
- 2** Lower the drum unit lock lever (B1).

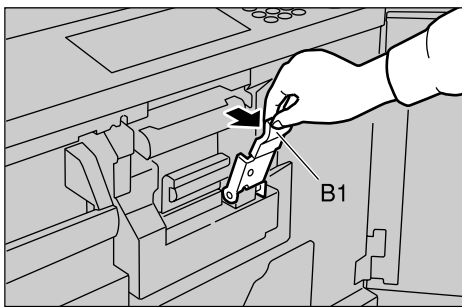

AJK151S

### Note

- Make sure the green light beside the drum unit lock lever is on before sliding out the drum. If the light is off, close the front door, wait for five seconds, and then open it.

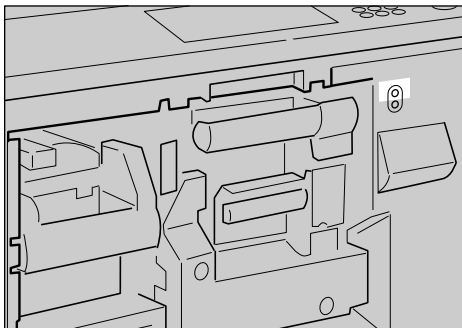

AJK147S

- 3** Pull the drum unit handle out slowly (B2).

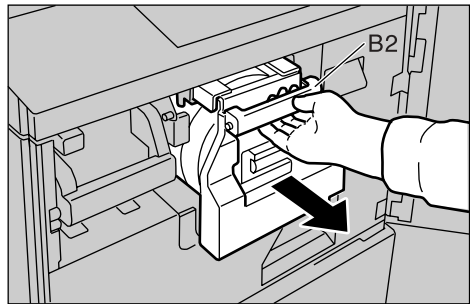

AJK302S

- 4** Lift the upper drum stay (B3) a little to unlock the drum unit, and then pull out the drum unit while holding the drum unit handle (B2) and the upper drum stay (B3).

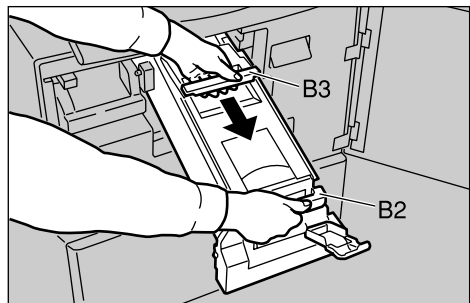

ZBH4260E

### Important

- Be careful not to let the drum unit fall.

- 5** Make sure the optional colour drum lock is securely set.

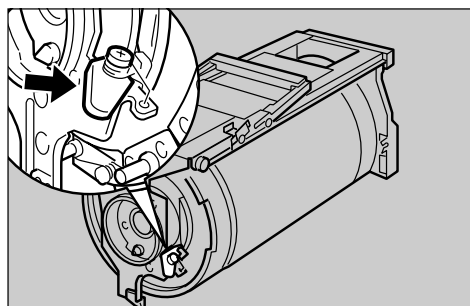

ZBH4220E

- 6** Insert the colour drum unit along the guide rail.

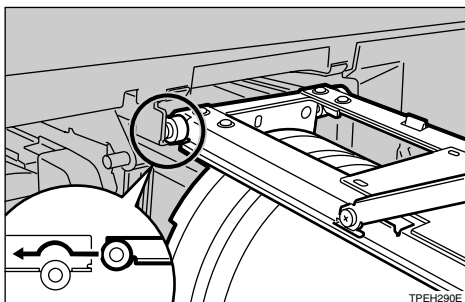

- 7** Lower the drum unit lock lever (B1) of the inserted drum.

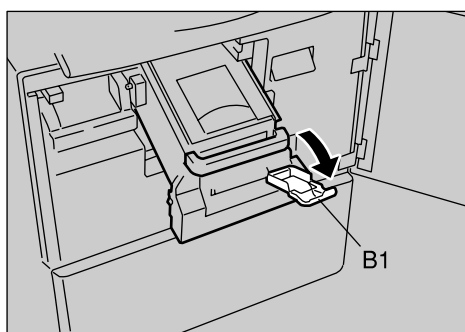

- 8** Slide in the drum unit until it locks in position.

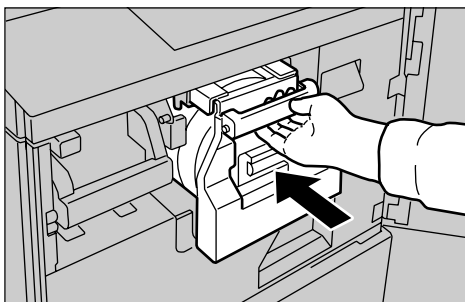

- 9** Lift drum unit lock lever (B1).

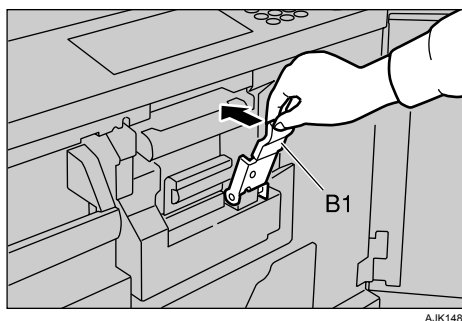

- 10** Close the front door.

**Note**

- Make sure that the **Open Cover/Unit** indicator turns off, and the colour drum status message appears on the display panel.

---

## Making Colour Prints

---

- 1** Make sure that the colour drum status message displays on the display panel.
- 2** Place the originals.
- 3** Press the **[Start]** key.

## Printing in Two Colours

After printing in one colour, you can print in another colour on the same side of the print.

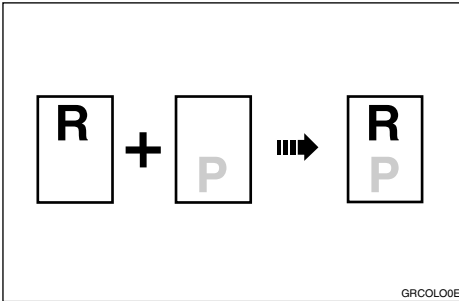

### Note

- ❑ Let the ink on the prints dry for a while before printing on them again.
- ❑ If the prints are not dry, the paper feed roller might become dirty. In this case, wipe the roller with a cloth.
- ❑ You cannot print in two colours at a time.

- 1** Prepare the two originals. Place the first original on the exposure glass or in the ADF.

#### ❖ Exposure glass

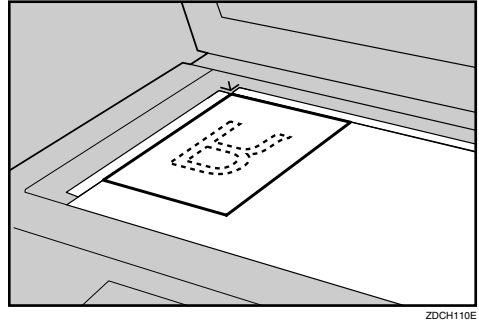

#### ❖ ADF

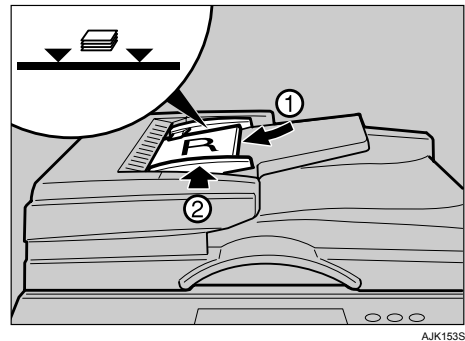

- 2** Enter the number of prints with the number keys.

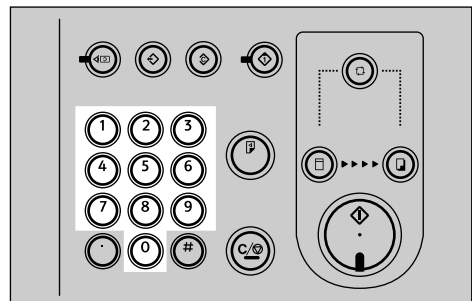

**3** Press the [Start] key.

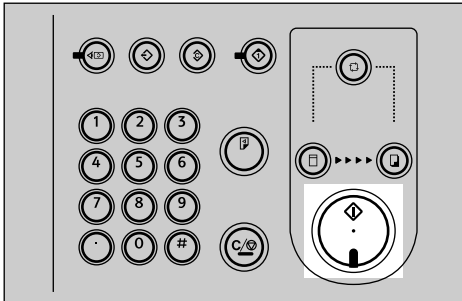

AJK108S

**4** Remove the prints from the paper delivery tray and place them on the paper feed tray again as shown in the illustration.

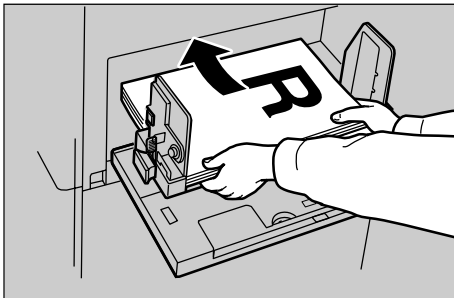

ZDZY010E

**5** Change the drum unit. See p.109 "Changing the Colour Drum Unit".

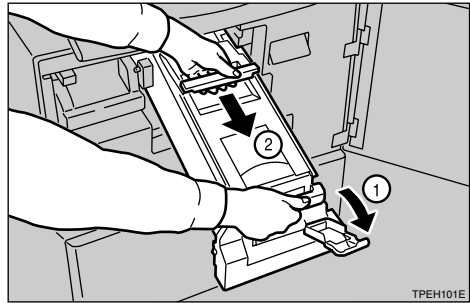

TPEH101E

**6** Place the second original, and then press the [Start] key.

3

# Changing the Drum Size

To save costs on master rolls and ink, you can shorten the length of each master by changing to an optional smaller drum.

## Printing Area (At 23°C/73°F, 65% RH)

### ❖ Metric version

A3 drum	More than 290 × 410 mm, 11.4" × 16.2"
A4 drum	More than 290 × 200 mm

### ❖ Inch version

11" × 17" drum	More than 290 × 420 mm, 11.4" × 16.6"
A4 (8½" × 11") drum	More than 11.4" × 7.8"

## Master Cut Length

A3 drum...320 × 539 mm, 12.5" × 21.3", 200 masters/roll

11" × 17" drum...320 × 549 mm, 12.5" × 21.7", 190 masters/roll

Optional A4 drum...320 × 334 mm, 12.5" × 13.2", 320 masters/roll

### Note

- For changing the drum unit, see p.109 "Changing the Colour Drum Unit".

# Combination Chart

This combination chart shows which functions can be used together.

	Can be used together.
×	Cannot be used together.
1	Cannot be used together. The first function selected takes priority.
2	Cannot be used together. The second function selected takes priority.

3

1. Function selected first	2. Function selected after																		
	Master Making Density	Selecting Original Type	Economy Mode	Auto Cycle	Cycle Setting	Preset Reduce / Enlarge	Zoom	Auto Reduce / Enlarge	Directional Magnification (%)	Directional Magnification (size)	Create Margin	Combine (2/4 images ⇒ 1 sheet)	Image Repeat (2/4/8/16 images ⇒ 1 sheet)	Custom Repeat	Erase Original Border	Erase Paper Border	Class Settings	Separate	
Master Making Density																			
Selecting Original Type																			
Economy Mode																			
Auto Cycle					2														
Cycle Setting				2															
Preset Reduce / Enlarge						2	2	2	2	2									
Zoom						2	2	2	2	2									
Auto Reduce / Enlarge						2	2	2	2	2									
Directional Magnification (%)						2	2	2	2	2									
Directional Magnification (size)						2	2	2	2	2									
Create Margin											1	1	1						
Combine (2/4 images ⇒ 1 sheet)											1	1	1	1					
Image Repeat (2/4/8/16 images ⇒ 1 sheet)											1	1	2						
Custom Repeat										1	1	1	2			1			
Erase Original Border															2				
Erase Paper Border																			
Class Settings																			
Separate																			
Image Overlay (Select online data)							1	1	1	1	1	1	1	1	1	1	1	1	1
Image Overlay (Select scanner)												1	1	1	1				
Image Overlay (Select stored file)							1	1	1	1	1	1	1	1	1				
Format Overlay (Scan + Scan)												1	1	1	1				
Format Overlay (Store + Store)		1	1				1	1	1	1	1	1	1	1	1	1			
Preset Stamp												1	1	1	1				
Make-up												1	1	1	1				
Skip Feed													1	1	1				
Auto Paper Select										1						2		2	
Adjusting the Position of Printed Images																			
Online	1	1					2	1	1	1	1	1	1	1	1	1	1	1	1
Storing File																			
Printing Stored Files	1	1																	
Printing Stored Files Using a Web Browser	1	1																	
Centring																			
Margin Adjustment																			
Changing the Printing Speed																			
Image Rotation																			

AJK320S

		2.Function selected after																
		Image Overlay (Select online data)	Image Overlay (Select scanner)	Image Overlay (Select stored file)	Format Overlay (Scan + Scan)	Format Overlay (Store + Store)	Preset Stamp	Make-up	Skip Feed	Auto Paper Select	Adjusting the Position of Printed Images	Online	Storing File	Printing Stored Files	Printing Stored Files Using a Web Browser	Centring	Margin Adjustment	Changing the Printing Speed
1.Function selected first	Master Making Density					2					2							
	Selecting Original Type					2		2			2							
	Economy Mode										2							
	Auto Cycle											2						
	Cycle Setting											2						
	Preset Reduce / Enlarge	2		2		2							2		2			
	Zoom	2		2		2						2		2	2			
	Auto Reduce / Enlarge	2		2		2			2			2		2	2			
	Directional Magnification (%)	2		2		2						2		2	2			
	Directional Magnification (size)	2		2		2						2		2	2			
	Create Margin	1	1	1	1	1	1	1					1	2	2	1	1	
	Combine (2/4 images ⇒ 1 sheet)	1	1	1	1	1	1	1					2	2	2	1	1	
	Image Repeat (2/4/8/16 images ⇒ 1 sheet)	1	1	1	1	1	1	1					2	2	2	1	1	
	Custom Repeat	1	1	1	1	1	1	1	1				2	2	2	1	1	
	Erase Original Border					2							2	2	2			
	Erase Paper Border	2								1			2					
	Class Settings	2										2						
	Separate																	
	Image Overlay (Select online data)		2	2	2	2	1	1	1	1			1	1	2	1	1	
	Image Overlay (Select scanner)	2		2	2	2	1	1					2	1	1	2	1	1
	Image Overlay (Select stored file)	2		2	2	2	1	1					2	1	1	2	1	1
	Format Overlay (Scan + Scan)	2		2	2	2	1	1					2	1	1	2	1	1
	Format Overlay (Store + Store)	2		2	2	2	1	1					2	1	1	2	1	1
	Preset Stamp	1	1	1	1	1	1	1					2	1	1	2	1	
	Make-up	1	1	1	1	1	1	1					2	1	1	2	1	1
	Skip Feed																	
	Auto Paper Select	2											2					
	Adjusting the Position of Printed Images																	
	Online		1	1	1	1	1	1	1	1			1	1	1	1	1	1
	Storing File		1	1	1	1	1	1	1				1	1	1	1	1	1
	Printing Stored Files		1	1	1	1	1	1	1				1	1	1	1	1	1
	Printing Stored Files Using a Web Browser		1	1	1	1	1	1	1				1	1	1	1	1	1
Centring		1	1	1	1	1	1	1				2	1	1	2	1	1	
Margin Adjustment		1	1	1	1	1	1	1				2	1	1	2	1	1	
Changing the Printing Speed																		
Image Rotation	x	x	x	x	x	x	x	x				2	x	x	x	x	x	

AJK321S





# 4. Troubleshooting

## If Your Machine Does Not Operate as You Want

The following chart gives explanations of common problems and messages. If other messages appear, follow the instructions displayed. If a malfunction or a misfeed occurs, the following messages will appear on the display.

### Note

- For “Troubleshooting” about printing from a computer, refer to the other manuals for this machine.

### ❖ When a Message is Displayed

Message	Causes	Solutions
Check the paper size and paper direction.	The paper is not placed in the same direction as the original.	Place the original in the same direction as the paper.
		If you press the <b>[Start]</b> key, the selected paper will be used for printing.
#### and paper size mismatch.	The paper you loaded does not match with the reproduction ratio you selected.	Set a paper size that matches the reproduction ratio you have selected and your original.
	The reproduction ratio selected by Auto Magnification mode is too big or too small.	
Set original.	You have not changed the original on the exposure glass before pressing the <b>[Start]</b> key.	Place the next original on the exposure glass or in the ADF.
	Original is not placed.	Place your originals.
Maximum quantity: ####	The number of prints exceeds the maximum print quantity.	You can change the maximum number of prints that can be made in one operation with User Tools. See p.161 “Maximum Print Quantity”.
Minimum quantity: ####	The number of prints does not exceed the minimum print quantity.	You can change the minimum number of prints that can be made in one operation with User Tools. See p.161 “Minimum Print Quantity”.
Drum Unit is not set correctly.	—	Slide in the drum until it clicks. Make sure that the drum is completely set in position.

Message	Causes	Solutions
Communication error has occurred. Turn the operation switch off then on.	—	Turn the operation switch off and on. If the message appears again, contact your service representative.
Print image is larger than the selected paper size. Change paper size.	The master image previously printed is larger than the paper. The image exceeds the paper size.	Make prints after pressing <b>[Exit]</b> and selecting the paper size again. <b>Note</b> <input type="checkbox"/> If you press <b>[Exit]</b> to erase the message and press the <b>[Start]</b> key, the machine starts to make the prints. However, the image might not fit on the paper.

4

 **When a service call message is shown on the display panel**

Press **[Exit]**. Then turn the main switch off and back on again. If a service code appears again, contact your service representative.

 **Note**

- If a service code appears on the display panel after you turn the main switch off and on a few times, do not continue turning it on and off. Leave the machine off.
- When you make masters continuously using originals with solid images, "SC203" tends to appear on the display panel. In this case, turn off the main switch and wait for a while. Then turn on the main switch.

# If you Cannot Make Clear Prints

## Faint Prints

If the machine is not used for a long period of time or you change the colour drum unit, the ink on the drum might dry causing print quality to deteriorate. To solve this problem, use Quality Start mode. See p.95 "Quality Start".

If the print density is still too light even if you use Quality Start mode, remake the master.

## Black Lines/Stained Prints

Check the exposure glass cover and clean it if dirty. See p.170 "Cleaning the exposure glass cover".

Check the exposure glass and clean it if dirty. See p.170 "Cleaning the Exposure Glass".

Check the sheet of the optional ADF and clean it if dirty. See p.171 "Cleaning the Auto Document Feeder".

### Note

- If black lines or stains still appear on prints even following the cleaning procedures above, please contact your service representative.

## Dirty Background

If the background of prints is dirty, the drum unit might be dirty.

### CAUTION:

- *If ink comes into contact with your eyes, rinse immediately in running water. For other symptoms, consult a doctor.*

### CAUTION:

- *Keep the ink or ink container out of reach of children.*

### CAUTION:

- *If ink is ingested, induce vomiting by drinking a strong saline solution. Consult a doctor immediately.*

### CAUTION:

- *If your skin comes into contact with ink, wash the affected area thoroughly with soap and water.*

**Note**

- ❑ To avoid getting dirty background prints when printing onto paper smaller than the original image, select a suitable reduction ratio or use larger print paper.
- ❑ When printing onto paper that does not absorb ink well, like postcards, the background of prints might be dirty. In this case, lower the printing speed or use Skip Feed mode to dry the ink on the prints.
- ❑ The drum unit is locked if the security mode is active. See p.97 “Security”.

**1** Turn off the power.

**2** Pull out the drum unit.

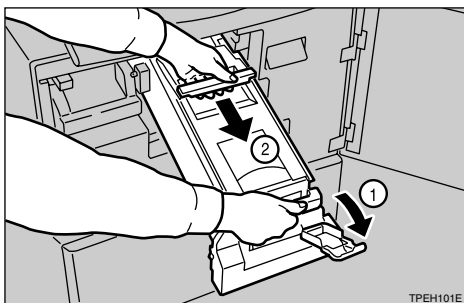

**Note**

- ❑ For taking out the drum unit, see p.109 “Changing the Colour Drum Unit”.

**3** While pressing the drum lock, turn the drum until you can see the trailing edge of the master.

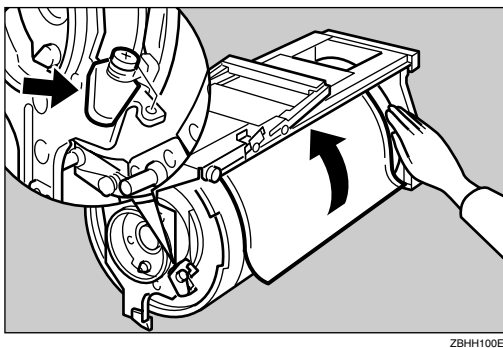

- 4 With a dry soft cloth, remove any ink that has accumulated on the trailing edge of the drum unit.

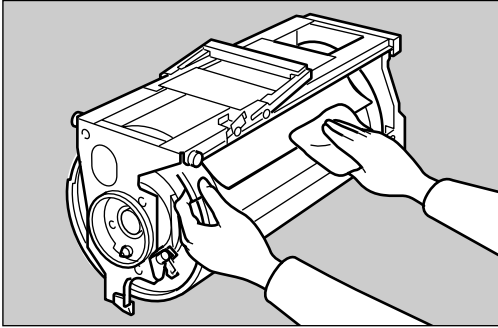

ZBHH210E

**Important**

- ❑ Do not use benzine, thinner, or other organic liquids—doing so can damage the machine.

4

- 5 Turn the drum unit and lock it after cleaning.

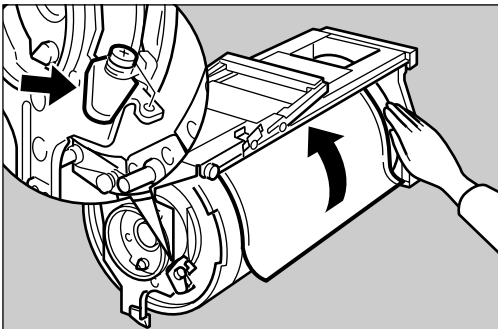

ZBHH100E

- 6 Insert the drum unit until it locks into position, and then lower the drum unit lock lever.

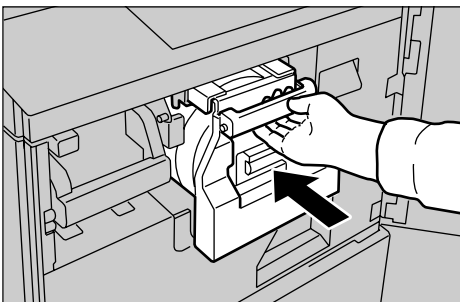

AJK149S

- 7 Close the front door.
- 8 Turn on the main switch.

## If You Cannot Make Prints as You Want

4

Problem	Causes	Solutions
Misfeeds occur frequently.	Improper paper type is selected.	Select proper paper type. See p.47 "Printing onto Various Kinds of Paper".
When you try to set several functions at a time, you cannot set some functions.	Some functions cannot be used together.	See p.114 "Combination Chart".
Parts of the image are not printed in Erase border mode.	Erase margin is too wide.	Set a narrower erase margin with User Tools. See p.76 "Erase Border".
	Edge margins of original are too narrow.	
Prints are blank or parts of the image are not printed.	The paper feed side plates are not set correctly.	Make sure that the paper feed side plates touch the paper lightly and the proper paper size is displayed in the display.
2nd printing with another drum is unsatisfactory.	The 1st print image is still wet.	Wait until the 1st image becomes dry.
An uneven solid image appears.	Large solid image wrinkles the master.	Increase the print speed or select photo mode.
"Double feed detected at output. Check the output." is displayed frequently.	The reverse or the face of printed paper is printed again.	Set to "OFF" in "Double Feed Warning" with User Tools.

### Combine

Problem	Causes	Solutions
Prints are blank or parts of the image are not printed.	Original size and orientation are not correct.	You cannot use originals of different sizes and orientation in Combine function. Use originals of same size and orientation.
Print image is not correct.	Original set order is not correct.	Place originals face up in the optional ADF. The first original should be on top.
		Place original face down on the exposure glass. The first original should be set first.

## Storing Files

Problem	Solution
<p>“Exceeded max. number of pages per file. Do you want to store the scanned pages as 1 file? ” appears.</p>	<p>The number of scanned pages exceeds the capacity per file of the machine.</p> <p>To store scanned pages as a file, press <b>[Yes]</b>. Scanned data is stored as a file in the machine.</p> <p>If you don't want to store scanned pages, press <b>[No]</b>. Scanning data will be cleared.</p>
<p>You forgot your password.</p>	<p>You can access password-protected files temporarily. Press <b>[Unlock]</b> in Temporarily Unlock Stored File in User Tools. See p.157 “Temporarily Unlock Stored Files”.</p> <p>. You can delete all stored files at once with User Tools. See p.157 “Delete All Files”.</p> <p>Make sure no important files are stored in the machine before deleting all stored files.</p>
<p>You cannot find out what is stored in a file.</p>	<p>Check the date or time column on the display in the machine.</p> <p>Check the contents of the document by printing the first page. Press the desired file on the display in the machine, and press <b>[Print 1st Page]</b> followed by the <b>[Start]</b> key.</p>
<p>Memory becomes full frequently.</p>	<p>Press <b>[Delete File]</b> to delete selected files, thereby increasing available memory.</p>

# 📄 Loading Paper

## Loading Paper into the Paper Feed Tray

### 🚫 Important

- ❑ Load paper when the paper feed tray is completely empty. If you add paper when some paper is left in the tray, it may cause multiple feeds or misfeeds.

### 🔍 Reference

For available paper sizes, see p.26 “Recommended Paper Size and Type”.

For loading paper into the LCIT, see p.125 “Loading Paper into LCIT”.

- 1** Raise the lock lever for the paper feed side plates to release the lock.

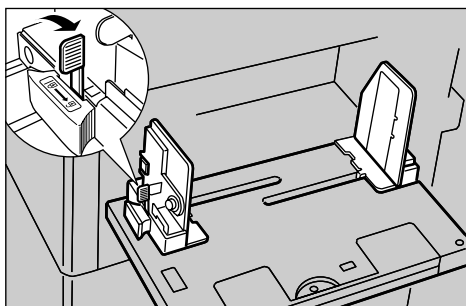

ACY011S

- 2** Load the paper in the paper feed tray.

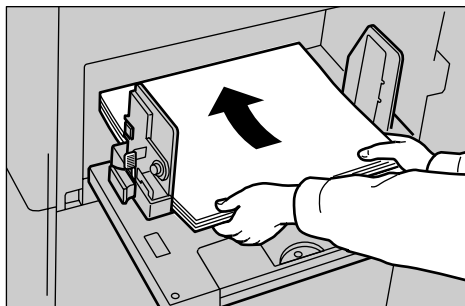

ZDCY020E

### 📌 Note

- ❑ Correct any paper curl before loading the paper.

- 3** Adjust the paper feed side plates to match the paper size.

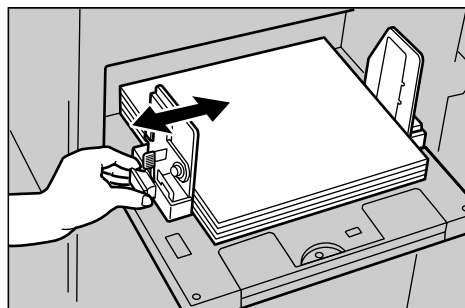

ZDCY030E



- 4** Push the lock lever for the paper feed side plates down to lock the side plates into position.

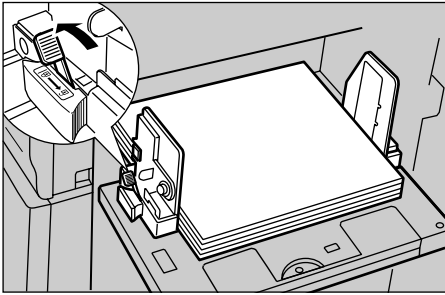

ZDCV041E

- 2** Tighten the screw to lock the side guides.

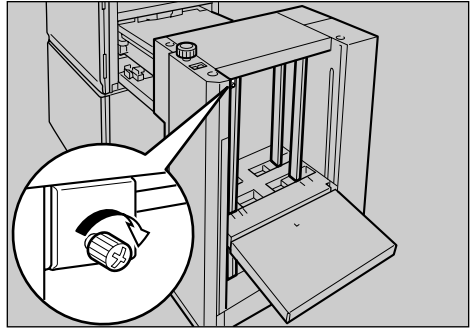

AJK166S

 **Note**

- Make sure that the paper size and orientation shown on the display panel match the size and orientation of paper loaded in the paper feed tray.

- 3** Load paper.

4

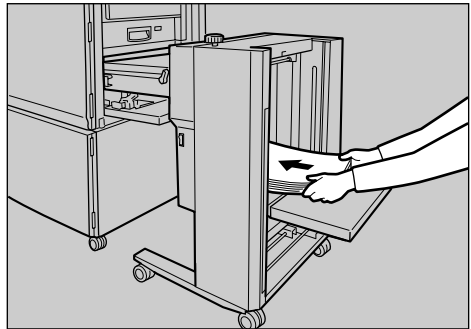

ABQ016S

## Loading Paper into LCIT

- 1** Turn the side guide adjustment knob to adjust the side guides to the paper size.

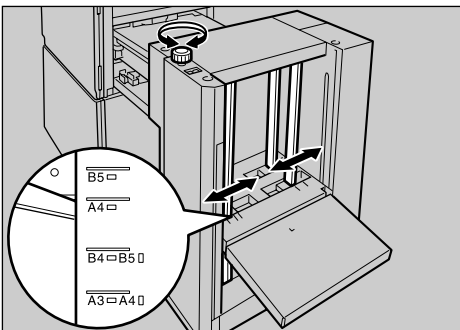

AJK158S

 **Note**

- The leading edge of the paper must touch the inside of the LCIT.

## Adding Ink

When  lights, it is time to supply ink.

**⚠ CAUTION:**

- *Keep the ink or ink container out of reach of children.*

**⚠ CAUTION:**

- *Be careful not to get ink on your clothes when replacing an ink container. Ink stains on clothes are hard to remove.*

**⚠ CAUTION:**

- *When disposing of a used ink container, reattach the cap to prevent ink from splattering.*

**⚠ CAUTION:**

- *If your skin comes into contact with ink, wash the affected area thoroughly with soap and water.*

**⚠ CAUTION:**

- *If ink comes into contact with your eyes, rinse immediately in running water. For other symptoms, consult a doctor.*

**⚠ CAUTION:**

- *If ink is ingested, induce vomiting by drinking a strong saline solution. Consult a doctor immediately.*

**⚠ Important**

- Faults may occur if you use ink other than the recommended type.
- Our products are engineered to meet high standards of quality and functionality, and we recommend that you use only the expendable supplies available at an authorized dealer.

**Note**

- Be sure to supply ink of the same colour as the current drum.
- Store ink in a cool, dry place. Do not store ink where it will be exposed to heat or direct sunlight.
- Store ink on a flat surface.

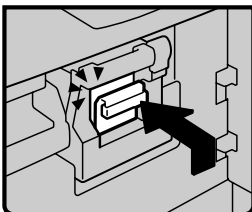
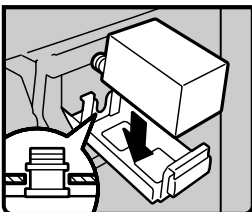
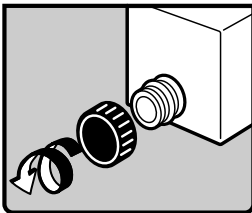
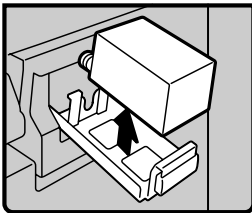
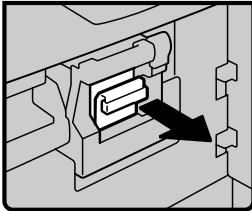

- 1: Open the front door.
- 2: Pull out the ink holder.
  
- 3: Remove the used ink cartridge.
  
- 4: Remove the cap of the new ink cartridge.
  
- 5: Insert the new cartridge into the ink holder.

**Note**

- Always supply ink of the same colour.

- 6: Return the ink holder to its original position until it clicks.
- 7: Close the front door.

The machine will start idling to supply ink to the drum.

## 🔧 Replacing the Master Roll

When 🟡 lights, it is time to replace the master roll. It also lights when the master roll is not set properly.

### ⚠️ Important

❑ Faults may occur if you use the master roll other than the recommended type.

### 📝 Note

❑ When the **Master End** indicator is lit, it is necessary to replace the master roll even if some master remains on the old roll.

4

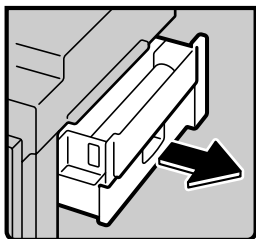

ACY040S

- 1: Pull out the master tray until it stops.

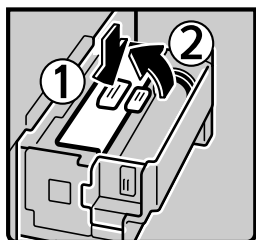

AJK304S

- 2: Push the button.
- 3: Open the master guide.

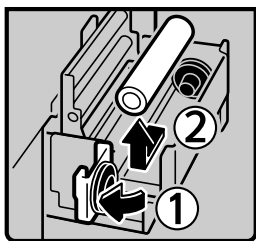

ACY042S

- 4: Open the master tray cover.
- 5: Remove the used master roll.

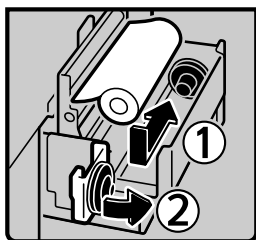

ACY043S

- 6: The new master roll must be positioned as shown in the illustration.
- 7: Close the master tray cover.



ACY044S

- 8: Insert the master roll.

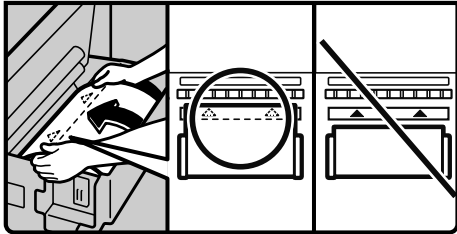

ACY045S

 **Note**

- Make sure the leading edge reaches the interior of the master holder.

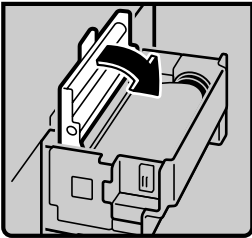

ACY046S

- 9: Close the master guide.

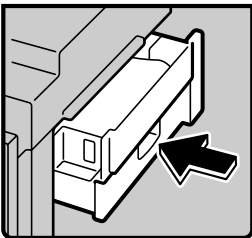

ACY047S

- 10: Push in the master tray until it stops.

# Clearing Misfeeds

## ⚠ CAUTION:

- *Be careful not to cut yourself on any sharp edges when you reach inside the machine to remove misfed sheets of paper or masters.*

## 🔧 Note

- ❑ After clearing misfeeds, make sure that all the doors, covers, and units are closed and the ⚡ indicator is off.
- ❑ To prevent misfeeds, do not leave any torn scraps of paper, originals, or masters in the machine.
- ❑ When clearing misfeeds, do not turn off the main switch. If you do, your print settings will be cleared.
- ❑ The master eject unit or the drum unit may be locked if the security mode is active. Enter the security code or ask your administrator if necessary.
- ❑ If misfeeds occur repeatedly, contact your service representative.

## “⚡ + A” Paper Misfeeds in the Paper Feed Section

- 1 Remove the misfed paper.

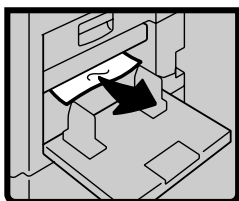

## 💡 To prevent paper misfeeds:

Check the following before restarting the printing run.

- Did you select an appropriate paper type with [Feed Tray Paper Type]?

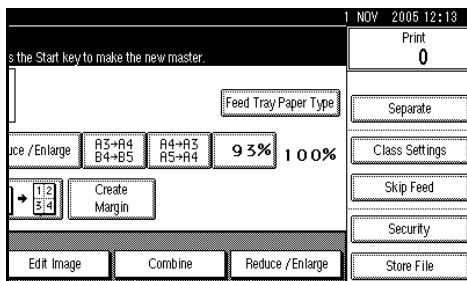

- Are the side pads in the correct positions?

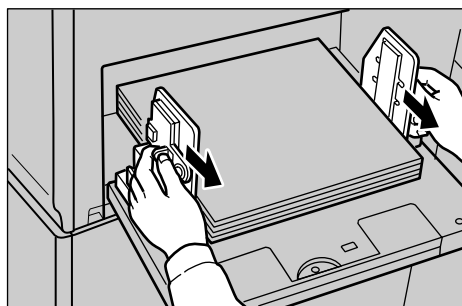

ZDCY140E

To print on thin paper (47.1 g/m<sup>2</sup>, 12.5 lb), slide the levers behind the paper feed side plates in the direction of the arrow (see illustration).

- When paper is curled, correct as shown.

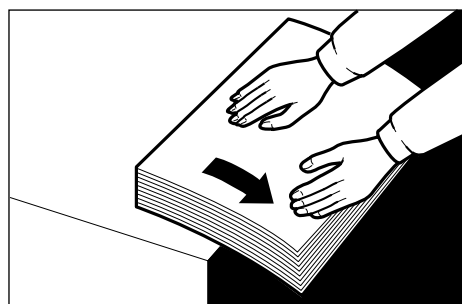

GRCURL0E

- When paper edges stick together or paper is not fed in, fan the paper as shown.

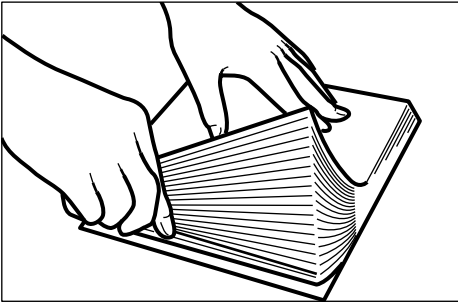

TPEY080J

- When printing onto postcards or thick paper, lower the printing speed to setting 1 or 2. See p.55 "Changing the Printing Speed".
- When a multiple feed occurs or the paper comes out skewed, make sure that the paper feed side plates are properly adjusted. When you load paper in the paper feed tray, make sure that the paper edge touches the back fence and paper is placed on the proper paper size scale. Only use paper where the leading edge has two right angle corners.



## "A + B" Paper Misfeeds in the Paper Feed Section

- 1 Open the front door.
- 2 Lower drum unit lock lever (B1).

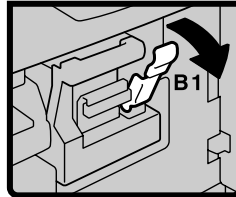

- 3 Take out the drum.

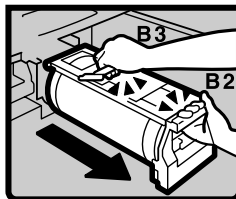
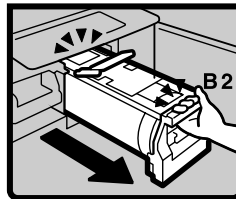

### Note

- For taking out the drum unit, see p.109 "Changing the Colour Drum Unit".

- 4 Gently pull out the misfed paper from the inside.

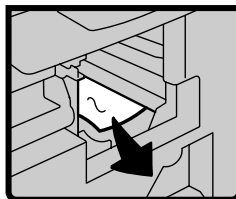

- 5** If you cannot remove the misfed paper, remove it from the paper feed tray.

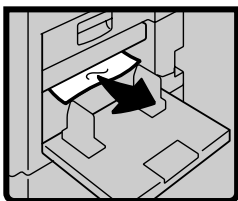

- 6** Set the drum unit and close the front door.

**Note**

- For setting the drum unit, see p.109 "Changing the Colour Drum Unit".

4

**To prevent paper misfeeds:**

See p.130 "⌘ + A" Paper Misfeeds in the Paper Feed Section".

**"⌘ + B" Paper or Master  
Wrapped Around the Drum**

When the master is wrapped around the drum

- 1** Open the front door.
- 2** Lower drum unit lock lever (B1).

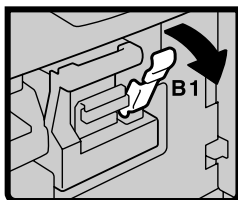

- 3** Take out the drum.

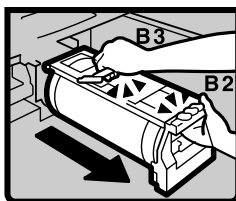
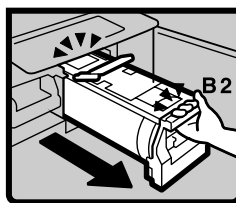

**Note**

- For taking out the drum unit, see p.109 "Changing the Colour Drum Unit".

- 4** While pressing the drum lock, grasp the edge of the master (the white area) and peel it off.

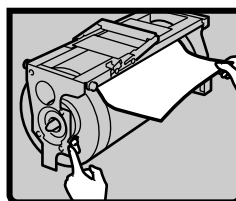

- 5** Return the drum lock to its original position.

- 6** Set the drum unit and close the front door.

**Note**

- For setting the drum unit, see p.109 "Changing the Colour Drum Unit".



**When paper is wrapped around the drum**

- 1** Open the front cover.
- 2** Lower drum unit lock lever (B1).

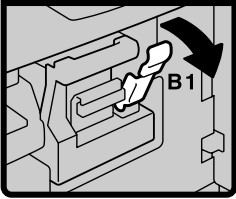

- 3** Take out the drum.

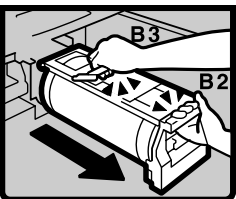
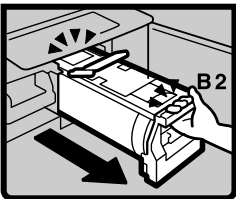

**Note**

- For taking out the drum unit, see p.109 "Changing the Colour Drum Unit".

- 4** Remove the misfed paper from the drum.

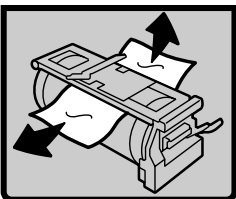

- 5** If you cannot find misfed paper around the drum (as in step 4), check the pressure cylinder. Remove any misfed paper.

- 6** Set the drum unit and close the front door.

**Note**

- For setting the drum unit, see p.109 "Changing the Colour Drum Unit".

**When paper is misfed inside the machine**

- 1** Open the front cover.
- 2** Lower drum unit lock lever (B1).

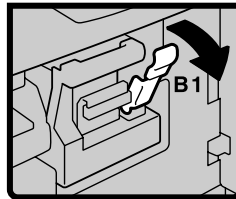

- 3** Take out the drum.

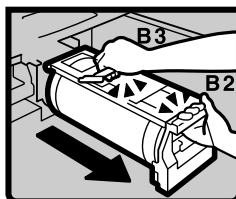
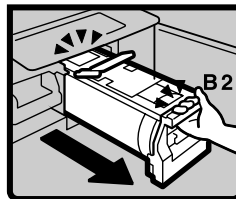

**Note**

- For taking out the drum unit, see p.109 "Changing the Colour Drum Unit".

- 4** Remove the misfed paper from the inside as shown in the illustration.

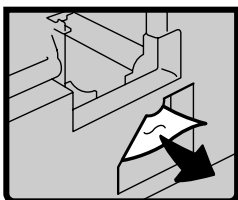

- 5** If you cannot remove the misfed paper, remove paper from the pressure cylinder.

- 6** Set the drum unit and close the front door.

**Note**

- For setting the drum unit, see p.109 "Changing the Colour Drum Unit".

**To prevent paper misfeeds:**

If the paper is curled or the original's leading edge margin is too narrow, the following action is necessary.

- When you use curled paper, correct as shown.

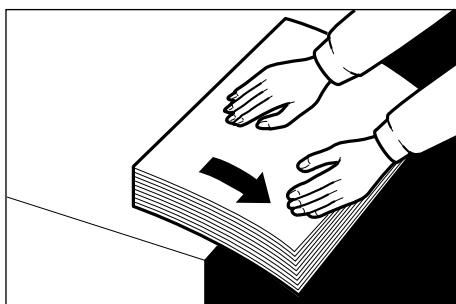

GRCURL0E

- When the leading edge margin of the original is less than 6 mm, 0.24" or there is a solid image on the leading edge, insert the original with the widest margin first or make a leading edge margin by making a print.

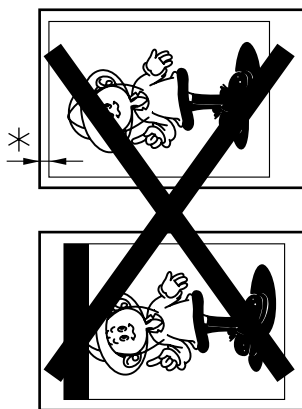

\*: Less than 6 mm, 0.24"

## “⌘ + C” Paper Misfeeds in the Paper Exit Section

- 1 Slowly, but firmly pull out the misfed paper.

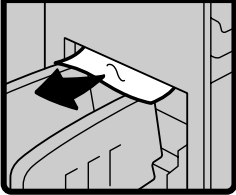

### To prevent paper misfeeds:

When thin paper misfeeds in the paper exit section, reduce the printing speed with the [◀][▶] of speed setting keys. See p.55 “Changing the Printing Speed”. If you cannot reduce the printing speed, close the trailing edge guides or move the end plate toward the paper delivery tray edge.

## “⌘ + D” Master Misfeeds in the Master Feed Section

- 1 Pull out the master tray until it stops.
- 2 Push the button and open the master guide.

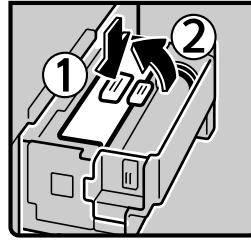

AJK304S

- 3 Rotate the spool backward to remove the remaining masters.

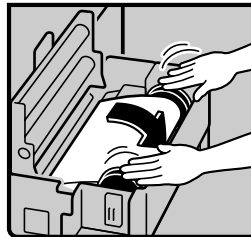

ACY071S

- 4 Open the master tray cover (1), and then remove the master roll (2).

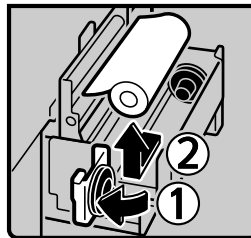

ACY072S

- 5** Reset the master roll (1), and then close the master tray cover (2).

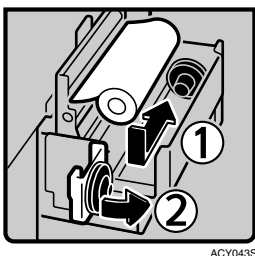

- 6** Position the master roll so that the edge reaches the interior of the master holder.

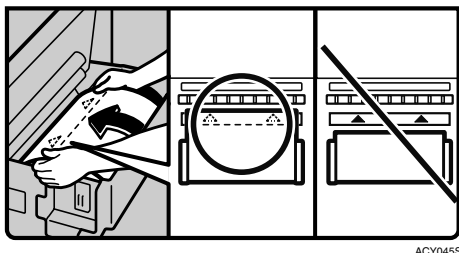

- 7** Close the master guide.

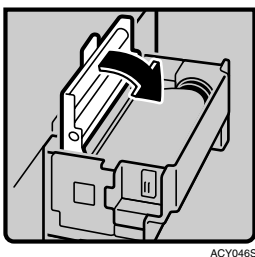

- 8** Push in the master tray until it stops.

## “⚙ + B + D” Master Misfeeds in the Master Feed Section

- 1** Open the front door.  
**2** Lower drum unit lock lever (B1).

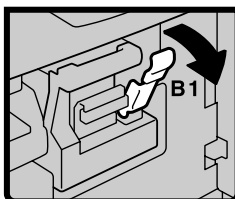

- 3** Take out the drum.

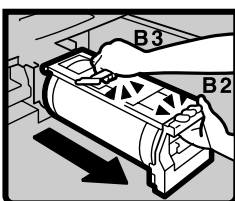
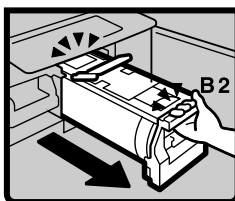

**Note**

- For taking out the drum unit, see p.109 “Changing the Colour Drum Unit”.

- 4** Pull out the misfed master from inside.

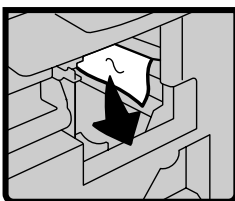

- 5** Set the drum unit and close the front door.

**Note**

- For setting the drum unit, see p.109 "Changing the Colour Drum Unit".

## "% + B + E" Master Misfeeds in the Master Eject Section

- 1** Open the front door.
- 2** Lower drum unit lock lever (B1).

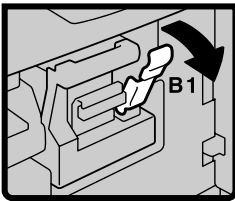

- 3** Take out the drum.

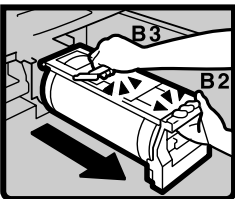
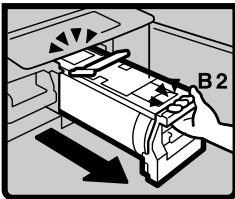

**Note**

- For taking out the drum unit, see p.109 "Changing the Colour Drum Unit".

- 4** Grasp handle (E1) and pull out the master eject unit until it stops.

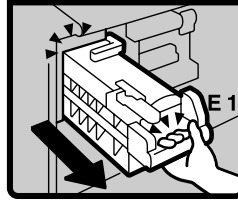

- 5** Pull out lever (E3) and remove the misfed master.

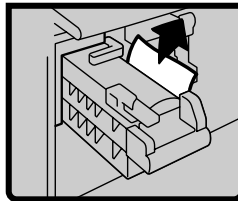
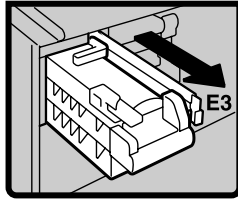

- 6** Return lever (E3) and the master eject unit to their original positions.

- 7** Set the drum unit and close the front door.

**Note**

- For setting the drum unit, see p.109 "Changing the Colour Drum Unit".

## “⚡ + E” Master Misfeeds in the Master Eject Section

- 1 Open the front door.
- 2 Grasp handle (E1) and pull out the master eject unit until it stops.

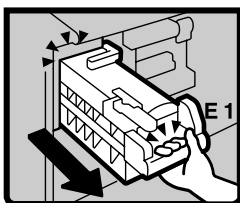

- 3 Check where the misfed master is. Remove the misfed master.

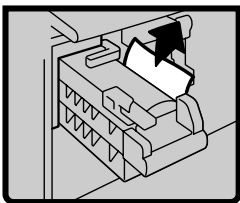

- 4 Return the master eject unit to its original position and close the front door.

💡 **If master misfeeds occur frequently**

If the master misfeeds frequently, fragments of the master might be left in the bottom of the master tray. Remove the fragments.

- 1 Slide out the master tray.

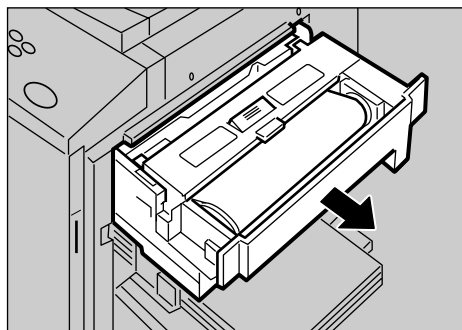

ACY048S

- 2 Open the cover at the bottom of the master tray while holding the lever and remove the fragments.

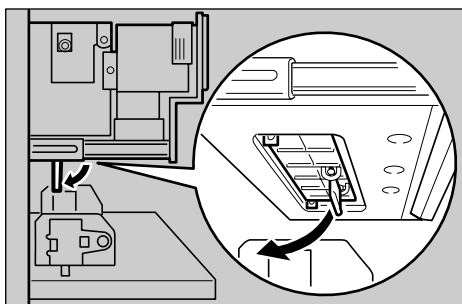

ZFXH201E

- 3 Close the cover and slide in the master tray.

**Note**

- ❑ Make sure that you securely close the cover before sliding in the master tray.

## “P” Original Misfeeds Occur in the Auto Document Feeder

**1** Open the ADF cover.

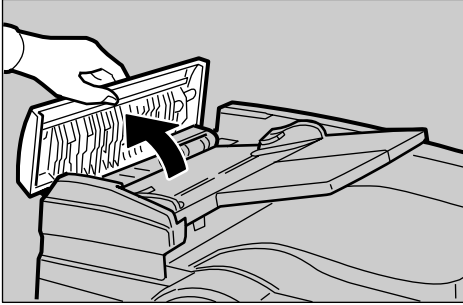

**2** Pull out the misfed original gently.

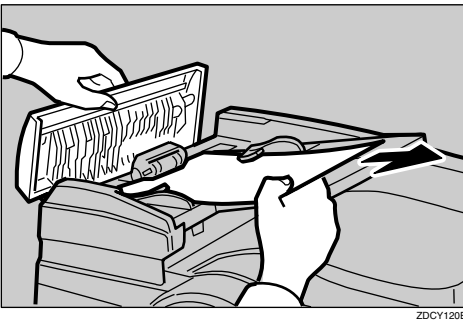

**3** If you cannot remove misfed originals as in step 2, open the ADF.

**4** Pull the green knob towards you and remove the misfed original.

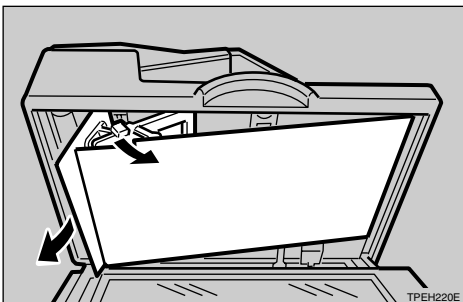

**5** Return the document feed sheet to its original position.

**6** Close the ADF cover until it clicks in position and if necessary, close the ADF.

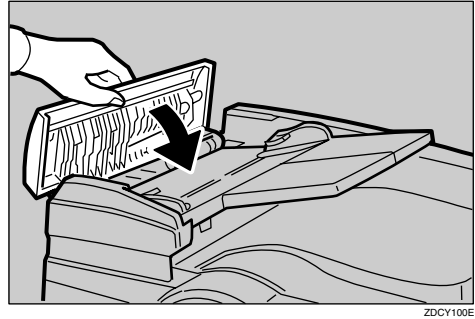

### To prevent originals misfeeding:

Placing some kinds of originals in the ADF may cause paper misfeeds. Place them on the exposure glass instead.

#### Note

- Do not mix different sizes of originals in the optional ADF.
- Remove staples or paper clips from originals. Fan originals that have had staples or paper clips removed.
- Do not stack originals above the limit mark.

## When Paper Misfeeds in the LCIT

- 1 Turn the cover release lever to unlock the cover of the intermediate feeding section of the LCIT.

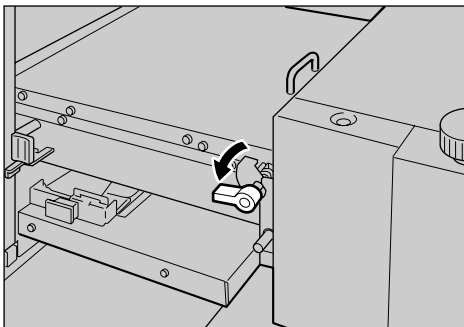

ABO029S

- 2 Open the cover, and then remove the paper.

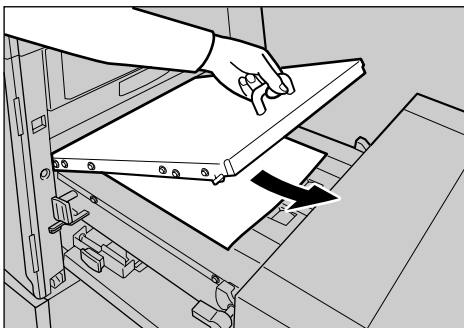

ABO031S

### **Important**

- ❑ When opening the cover, always hold the handle to prevent the cover from dropping and causing an injury.

### **Note**

- ❑ If you open the cover, be sure to remove the paper even if it is not misfed.
- ❑ When small size paper is misfed and cannot be removed, detach the LCIT, and then remove the paper.

- 3 Close the cover, and then move the cover release lever back to the original position.

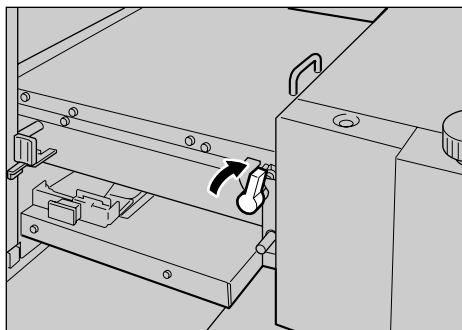

ABO030S

### **Note**

- ❑ If a paper misfeed message appears on the machine, remove the paper misfed in the machine also.



# Changing the Paper Size

## Changing the Paper Size of the Paper Feed Tray

- 1 Remove the paper from paper feed tray.

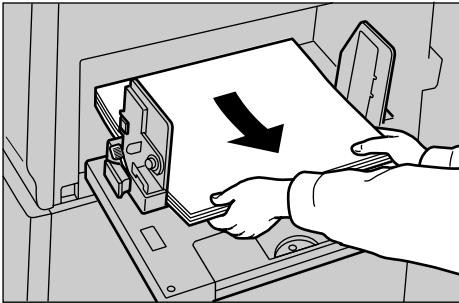

ACY009S

The paper feed tray will lower.

- 2 Make sure that the paper feed side plates knob lock lever is raised (lock is released), and then grasp the paper feed side plates knob and adjust the paper feed side plates to match the paper size.

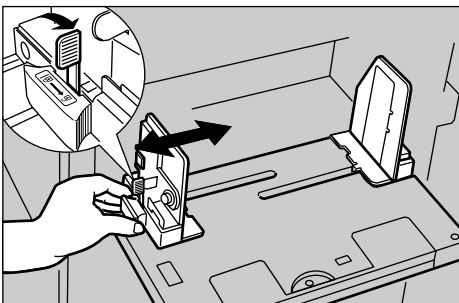

ACY007S

### Important

- Always adjust the position with the lock lever for the paper feed side plates in the raised position (lock released).

- 3 Place the paper on the paper feed tray.

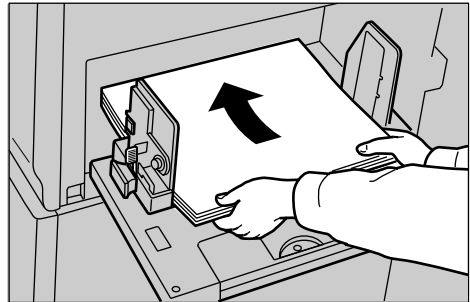

ACY008S

### Note

- Correct the paper curl before loading the paper. If you cannot do so, stack the paper with the curl face down.

- 4 Make sure that the paper feed side plates are touching both sides of the paper, and then push the lock lever for the side plates down to lock the side plates into position.

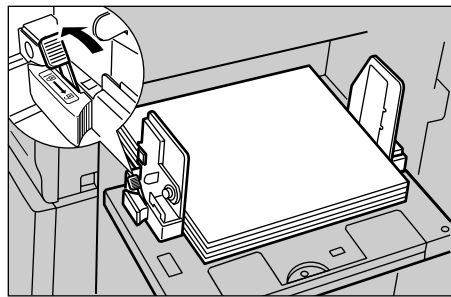

ZDCY041E

### Important

- Always make sure that you push the lock lever for the side plates down to lock the side plates into position.

### Note

- Make sure that the paper size and orientation in the display panel correspond with the actual paper size and orientation set on the paper feed tray.

## Changing the Paper Size of LCIT

- 1 Take the paper stack out of the input tray.

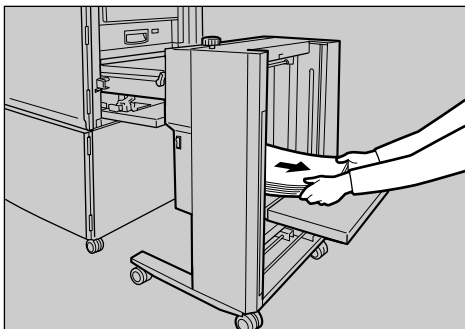

ABO033S

- 2 Remove the paper remaining in the intermediate feeding section.

### Reference

p.140 "When Paper Misfeeds in the LCIT"

- 3 Loosen the screw to unlock the side guides.

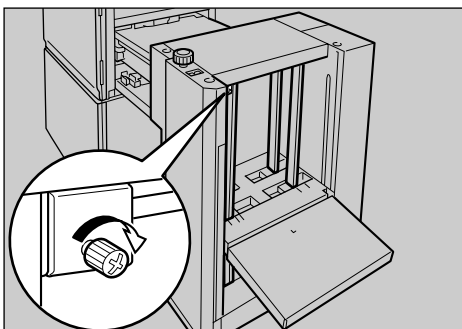

AJK166S

- 4 Turn the side guide adjustment knob to adjust the side guides to the new paper size.

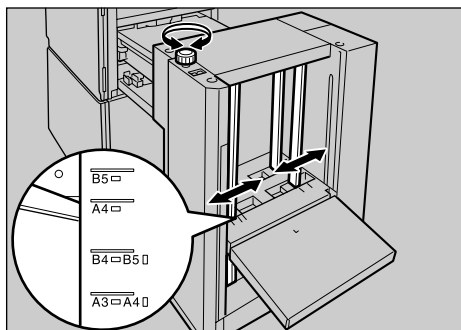

AJK158S

- 5 Tighten the screw to lock the side guides.

- 6 Load paper.

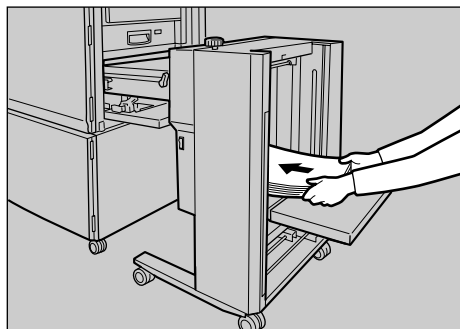

ABO016S

### Note

- The leading edge of the paper must touch the inside of the LCIT.

# ☒ When the Open Cover/Unit Indicator Lights

A message is displayed explaining the place where the doors/covers are not properly closed.

## ❖ Front door

Close the front door completely.

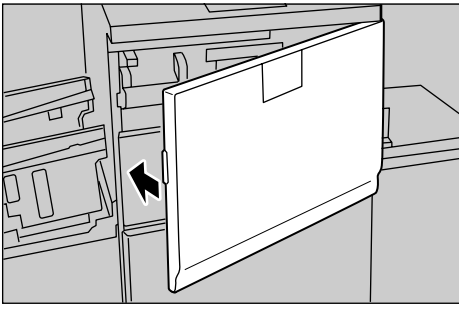

AJK112S

## ❖ Optional ADF cover

Close the ADF over until it locks in position.

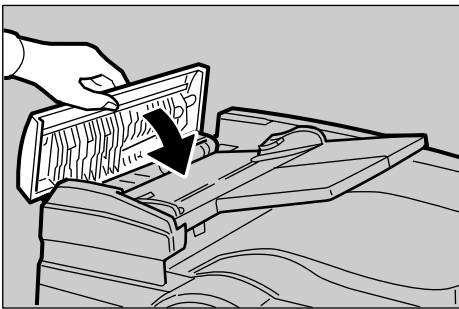

ZDCY100E

## ❖ Optional LCIT Unit

① Close the LCIT Unit cover.

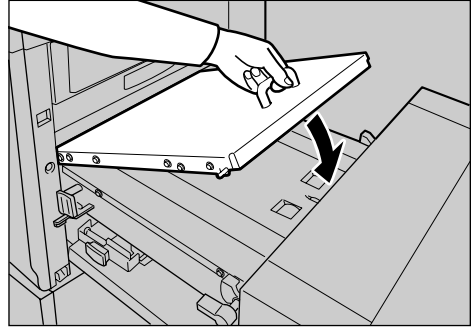

ACY052S

② Move the cover release lever back to the original position.

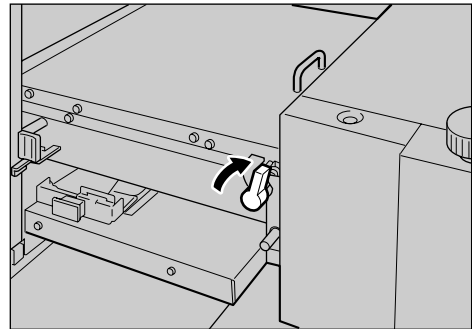

ABO030S

## ❖ Optional LCOT Unit

Lower the end plate arm.

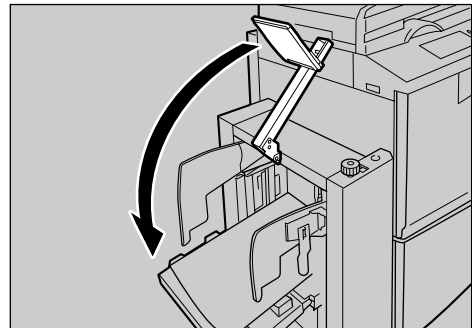

AJK164S

## ↶ Removing the Used Master

When ↶ lights, it is time to empty the master eject unit. It also lights when the master eject unit is not set properly.

### Note

- Ink is easily removed from skin by waterless hand cleaners followed by washing with soap and water.
- Be careful not to get any ink on your clothing while emptying the master eject unit.
- When Higher Security is on, you have to enter the security code to unlock the master eject unit.

4

**1** Prepare a container for the used master.

**2** Open the front door.

**3** Use handle (E1) to pull out the master eject unit until it stops.

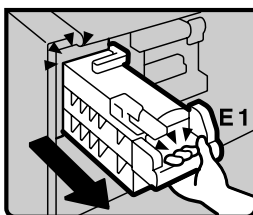

**4** Pull up handle (E2) and pull out the master eject unit completely.

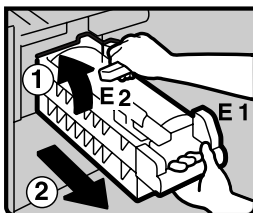

**5** Hold the master eject unit upper handle and turn it clockwise with one hand while holding handle (E1) with other hand (1).

**6** Remove the used master by pushing down the handle (1) towards the waste container (2).

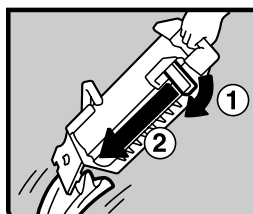

### Note

- If you cannot remove the used master completely, repeat step **6** until all the master is removed.

**7** Reinstall the master eject unit, making sure it clicks into position.

**8** Close the front cover.

# When Multiple Sheets Are Fed at the Same Time

Follow the procedure below to correct a multiple sheet feed problem of the LCIT.

- 1** Adjust the feeding pressure lever of the LCIT according to the thickness of the paper loaded.

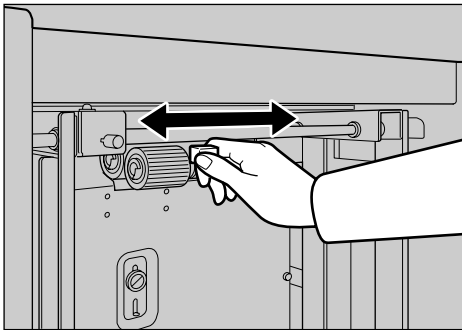

ABQ025S

## Note

- The appropriate feeding pressure lever positions according to the weight of the paper are as follows.

	Metric version	Inch version
Thick	127.9 – 209.3 g/m <sup>2</sup>	34.0 – 55.6 lb.
Standard	52.3 – 127.9 g/m <sup>2</sup>	13.9 – 34.0 lb.
Thin	47.1 – 52.3 g/m <sup>2</sup>	12.5 – 13.9 lb.

- If multiple sheets of paper are fed at the same time when the feeding pressure lever is set to Standard, set the feeding pressure lever to Thin.
- If paper is not fed at all when the feeding pressure lever is set to Thin, set the feeding pressure lever to Standard.
- Paper heavier than 127.9 – 209.3 g/m<sup>2</sup> (34.0 – 55.6 lb.) is categorized as thick paper. However, for B5 JIS paper heavier than 127.9 g/m<sup>2</sup> (34.0 lb.), set the feeding pressure lever to Standard.
- When paper is still not fed properly even after the feeding pressure lever is adjusted, increase the paper feeding pressure of the machine.

- 2** If the problem still persists, take the paper out and fan it before loading it again.

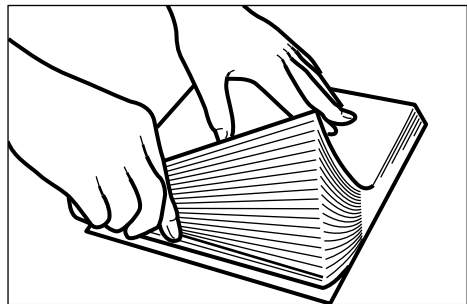

TPEY080J

# When Prints Are Not Delivered in a Neat Stack

## When Printing on Small Size Paper

- 1 Slightly lower the end plate to raise the screw.

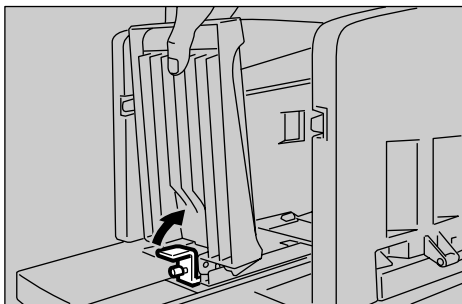

ZADH110J

- 2 Adjust the angle of the end plate by turning the screw clockwise or counterclockwise.



ABL034S

### 💡 When paper sides do not stack neatly

Adjust the paper delivery side plates to a size a little larger than the paper size.

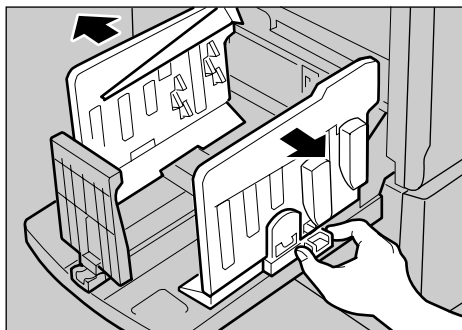

ABL046S

## User Tools Menu

---

### System Settings

---

#### ❖ General Features (See p.153 “General Features”.)

	Default
Panel Beeper	<i>Warning Only</i>
mm/inch	<ul style="list-style-type: none"><li>• Metric version: <i>mm</i></li><li>• Inch version: <i>inch</i></li></ul>

#### ❖ Timer Settings (See p.153 “Timer Settings”.)

	Default
Set Date	--
Set Time	--
System Auto Reset Timer	<i>off</i>
Energy Saver Timer	<i>3 min</i>
Auto Off Timer	<i>off</i>

❖ **Mode Settings (See p.154 “Mode Setting”).**

	<b>Default</b>
Energy Saver Option	<i>Energy Saving</i>
Auto Cycle	<i>On</i>
Ignore Paper Size	<i>Do not Ignore</i>
Longer Paper	<i>Do not Use</i>
Skip Feed	<i>2 times</i>
Auto Quality Start Setting	<i>On</i>
No.of Idling Rotations: Auto Quality Start	--
No.of Idling Rotations: Quality Start	<i>7 times</i>
Deflector Angle	<i>Auto</i>
Auto Class	<i>Stop</i>
Master/Ink Remaining Volume	<i>Off</i>
Paper Type	<i>Standard</i>
Paper Type: User1-2	<i>Standard: No Feed</i>
Master Cut Length	<i>Auto</i>
Double Feed Warning	<i>Off</i>

❖ **Interface Settings**

- For details about network settings, see “User Tools Menu (System Settings)”, *Network Guide*.

❖ **Administrator Tools (See p.156 “Administrator Tools”).**

	<b>Default</b>
User Code Management	<i>Off</i>
Key Operator Code	<i>Off</i>
Restricted Access	<i>Off</i>
Security Option	<i>Normal</i>
Security Timer	<i>Off</i>
Display/Clear/Print Counter per User	--
Program/Change/Delete User Code and Name	--
Auto Delete File	<i>No</i>
Delete All Files	--
Temporarily Unlock Stored Files	<i>Do not Unlock</i>



## Master Making/Print Settings

### ❖ Reproduction Ratio (See p.158 “Reproduction Ratio”.)

	Default
Shortcut Reduce/Enlarge 1-3	Metric version <ul style="list-style-type: none"> <li>•Shortcut Reduce/Enlarge 1: 71%</li> <li>•Shortcut Reduce/Enlarge 2: 141%</li> <li>•Shortcut Reduce/Enlarge 3: 93%</li> </ul> Inch version <ul style="list-style-type: none"> <li>•Shortcut Reduce/Enlarge 1: 74%</li> <li>•Shortcut Reduce/Enlarge 2: 155%</li> <li>•Shortcut Reduce/Enlarge 3: 93%</li> </ul>
Enlarge 1-4	Metric version <ul style="list-style-type: none"> <li>•Enlarge 1: 115%</li> <li>•Enlarge 2: 122%</li> <li>•Enlarge 3: 141%</li> <li>•Enlarge 4: 200%</li> </ul> Inch version <ul style="list-style-type: none"> <li>•Enlarge 1: 121%</li> <li>•Enlarge 2: 129%</li> <li>•Enlarge 3: 155%</li> <li>•Enlarge 4: 200%</li> </ul>
Priority Setting:Enlarge	Metric version 141% Inch version 155%
Reduce 1-5	Metric version <ul style="list-style-type: none"> <li>•Reduce1: 50%</li> <li>•Reduce2: 61%</li> <li>•Reduce3: 71%</li> <li>•Reduce4: 82%</li> <li>•Reduce5: 87%</li> </ul> Inch version <ul style="list-style-type: none"> <li>•Reduce1: 50%</li> <li>•Reduce2: 65%</li> <li>•Reduce3: 74%</li> <li>•Reduce4: 77%</li> <li>•Reduce5: 85%</li> </ul>
Priority Setting:Reduce	Metric version 71% Inch version 74%
Ratio for Create Margin	93%
Reduce/Enlarge Priority	<i>Reduce</i>

❖ **Original Setting (See p.159 “Original Setting”.)**

	<b>Default</b>
Master Making Density	<i>Normal</i>
Original Type	<i>Text</i>
Text/Photo Contrast	<i>Normal</i>
Photo Contrast	<i>Normal</i>
Photo (Screen)	<i>Normal</i>
Background Correction	<i>Off</i>

❖ **Edit Setting (See p.159 “Edit Setting”.)**

	<b>Default</b>
Combine/Image Repeat Separation Line	<i>None</i>
Erase Original Border Width	Metric version: <i>2 mm</i> Inch version: <i>0.1”</i>
Erase Paper Border Width	Metric version: <i>2 mm</i> Inch version: <i>0.1”</i>
Stamp Type Defaults	<i>CONFIDENTIAL</i>
Stamp Size	<i>1 X</i>
Stamp Density	<i>Normal</i>
Stamp Position	Metric version <ul style="list-style-type: none"> <li>• Position: <i>Top Right</i></li> <li>• Top Margin: <i>24 mm</i></li> <li>• Right Margin: <i>24 mm</i></li> </ul> Inch version <ul style="list-style-type: none"> <li>• Position: <i>Top Right</i></li> <li>• Top Margin: <i>1.0”</i></li> <li>• Right Margin: <i>1.0”</i></li> </ul>

❖ **Others (See p.160 “Others”.)**

	<b>Default</b>
Ignore ADF Original Size	<i>Do not Ignore</i>
Ignore Exposure Glass Original Size	<i>Do not Ignore</i>
Cancel Combine/Repeat Setting	<i>Do not cancel</i>
Auto Separate (Class)	<i>On</i>
Auto Rotation	<i>On</i>
Minimum Print Quantity	<i>0 sheet(s)</i>
Maximum Print Quantity	<i>9999 sheet(s)</i>
Economy Mode	<i>Off</i>

❖ **Prog.Key Settings (See p.161 “Prog.Key Settings”.)**

	<b>Default</b>
Function Key:F1–F5	<ul style="list-style-type: none"> <li>• F1: <i>1 Sided → 1 Sided Combine: 2 originals</i></li> <li>• F2: <i>1 Sided → 1 Sided Combine: 4 originals</i></li> <li>• F3: <i>Create Margin</i></li> <li>• F4: <i>Off</i></li> <li>• F5: <i>Off</i></li> </ul>

# Accessing User Tools (System Settings/Master Making/Print Settings)

User Tools allow you to change or set defaults.

## Note

- ❑ Operations for system settings are different from normal operations. Always quit User Tools when you have finished.
- ❑ Any changes you make with User Tools remain in effect even if the main switch or operation switch is turned off, or the **[Clear Modes]** key is pressed.

5

## Changing Default Settings

### Note

- ❑ If a key operator code is already set, the operator code entry display appears. Enter the key operator code, and then press **[OK]**. See p.156 “Key Operator Code”.

- 1** Press the **[User Tools]** key.

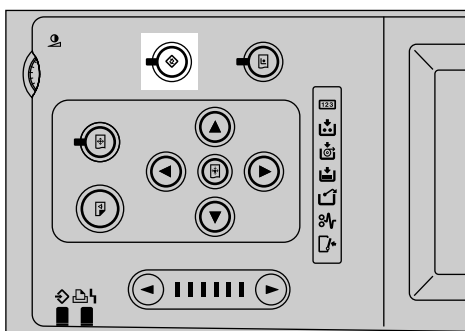

- 2** Press **[System Settings]** or **[Master Making / Print Settings]**.

- 3** Select the desired menu, and then press the appropriate key.

- 4** Change settings by following instructions on the display panel, and then press **[OK]**.

## Note

- ❑ To cancel changing settings and return to the initial display, press the **[User Tools]** key.

## Quitting User Tools

- 1** Press the **[User Tools]** key.

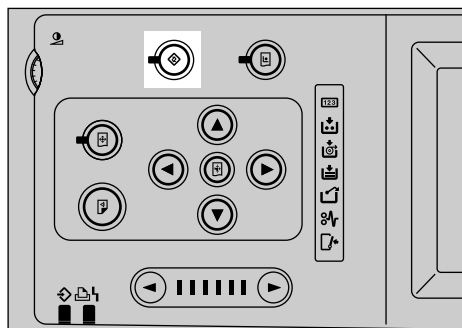

## Note

- ❑ You can also exit from User Tools by pressing **[Exit]**.

# Settings You Can Change with User Tools

---

## System Settings

---



---

### General Features

---

#### ❖ Panel Beeper

Turns the beeper on or off.

- All On (The beeper sounds when you press a key or when warning messages appear on the display.)
- Warning Only (The beeper sounds only when warning messages are shown on the display and not when you press a key.)
- All Off (The beeper does not sound at all.)

#### Note

- Default: *Warning Only*

#### ❖ mm/inch

You can select the units of measurement shown on the display.

#### Note

- Default:
  - Metric version: *mm*
  - Inch version: *inch*

---

### Timer Settings

---

#### ❖ Set Date

You can set the date for the machine's internal clock using the number keys.

#### Note

- To change between year, month and day, press [←] and [→].

#### ❖ Set Time

You can set the time for the machine's internal clock using the number keys.

#### Note

- To change between hours, minutes and seconds, press [←] and [→].

#### ❖ System Auto Reset Timer

The System Reset setting automatically switches to the initial screen when no operations are in progress, or when an interrupted job is cleared. This setting determines the system reset interval.

#### Note

- Default: *off*
- The time can be set from 1 to 5 minutes.

#### ❖ Energy Saver Timer

You can set the time that the machine waits before switching to lower power mode after printing has finished or the last operation is performed.

The time can be set from 1 minute to 120 minutes.

#### Note

- Default: *3 min*
- When in "Energy Saver Mode", the machine is ready for use within 240 seconds.

#### ❖ Auto Off Timer

You can select to use the auto off timer and set the daily power off time.

#### Note

- Default: *Off*

## Mode Setting

### ❖ Energy Saver Option

You can select to **[Energy Saving]** or **[Auto Off]**.

#### Note

Default: *Energy Saving*

### ❖ Auto Cycle

Specifies whether Auto Cycle mode is selected at power on.

#### Note

Default: *On*

### ❖ Ignore Paper Size

If you are making prints on custom size paper and the original image does not entirely appear on the print, select "Ignore". The machine will not detect the paper length.

#### Note

Default: *Do not Ignore*

### ❖ Longer Paper

You can select "Use" to allow the use of paper longer than 432 mm, 17.0".

#### Note

Default: *Do not Use*

### ❖ Skip Feed

You can select **[Display]** or **[Do not Display]** and set the number of Skip Feed.

#### Note

Default: *2 times*

The time can be set from 2 to 9 times.

### ❖ Auto Quality Start Setting

You can select **[On]** to have the machine automatically carry out a few idle spins when the power is turned on. When selecting **[Off]**, you can restore the density by making a few extra prints or by using the Manual Quality Start mode.

#### Note

Default: *On*

### ❖ No. of Idling Rotations: Auto Quality Start

You can select how many times the drum unit idles after the displayed time periods have passed in Auto Quality Start mode.

#### Note

Default settings are follows.

		Time period			
		0 - 4 hours	4 - 24 hours	24 - 72 hours	Over than 72 hours
Temperature	Low Tmp. *1	0	7	7	7
	Normal Tmp. *2	0	5	5	5
	High Tmp. *3	0	5	5	5

\*1 (Below 19°C or 66.2°F)

\*2 (19 - 29°C, 66.2 - 84.2°F)

\*3 (Over 29°C or 84.2°F)

To increase the print image density, increase the number of drum rotations, and vice versa.

❖ **No.of Idling Rotations: Quality Start**

When you use the Quality Start mode, you can select how many times the drum unit idles.

 **Note**

Default: *7 times*

❖ **Deflector Angle**

You can change the angle of the wing guide depending on the paper type you use.

- Up (Select this setting when standard thickness or thin paper misfeeds at the paper exit section occur frequently.)
- Down (Select this setting when A4 – B5 JIS, 8<sup>1</sup>/<sub>2</sub>" × 11" thick paper is not delivered properly to the paper delivery tray.)

 **Note**

Default: *Auto*

❖ **Auto Class**

Instead of using the Separate mode, you can make the following settings:

- Start Automatically (After the last page of each printing set is fed out to the paper delivery tray, the machine stops for a few seconds. Then, the next cycle begins.)
- Stop (After the last page of each printing set is fed out to the paper delivery tray, the machine stops. If you press the **[Start]** key, the next cycle begins.)

 **Note**

Default: *Stop*

❖ **Master/Ink Remaining Volume**

Specifies whether you can check the amount of ink and master.

- **[Off]** (You cannot check the remaining amount of ink or master.)
- **[On (Below half)]** (When the remaining amount of ink or master is less than half, the display panel indicates these amounts when you turn on the main switch.)

 **Note**

Default: *Off*

❖ **Paper Type**

You can select the paper type.

 **Note**

Default: *Standard*

❖ **Paper Type: User1–2**

You can register a frequently used paper type and have it shown on the paper type menu as **[User 1]** or **[User 2]**.

 **Note**

Default: *Standard: No Feed*

- ① Select the paper type.
  - Standard: "No feed" "Double feed"
  - Thick Paper: "No feed" "Double feed" "Medium"
- ② Press **[OK]**.

❖ **Master Cut Length**

The machine determines the master length according to the number of originals placed in the optional ADF and the paper sizes. If you wish to use A3, 11" × 17" master regardless of the number of originals set and the paper sizes, select "A3".

 **Note**

Default: *Auto*

❖ **Double Feed Warning**

Specifies whether a warning is displayed or not when a double feed is detected.

 **Note**

Default: *Off*

5

---

**Administrator Tools**

---

❖ **User Code Management**

You can select whether or not to use User Code mode. If user codes are turned on, users must enter their user codes before they can operate the machine. The machine keeps count of the number of copies made under each user code. User code must be registered for User Code Management. See p.162 "User Code".

 **Note**

Default: *Off*

❖ **Key Operator Code**

You can specify whether or not to use key operator codes to control Administrator Tools settings for access codes.

 **Note**

Default: *Off*

If you select **[On]**, enter the key operator code (max.4 digits) using the number keys, and then select **[Partial]** or **[All Initial Settings]** to set the access limit.

- If you selected **[Partial]**

A key operator code is only required to access Administrator Tools for System Settings.

- If you selected **[All Initial Settings]**

A key operator code is required to access all items in System Settings, Master Making/Print Settings, and Online Print Features.

If you select **[On]**, you must enter an access code to access the Key Operator Code display.

❖ **Restricted Access**

In Key Counter mode, you have to set the key counter before making prints. (To turn on Key Counter mode, contact your service representative.) If Key Counter mode is on, Restricted Access is turned on automatically. If you turn Restricted Access off, you can make prints without inserting the key counter.

 **Note**

Default: *Off*



❖ **Security Option**

You can specify the setting of security mode.

 **Note**

- Default: *Normal*
- You have to set a security code (4 digits) to enable Higher Security mode.
- When selecting Higher Security mode, a security mark  appears on the left side of the date, in the upper right of the display panel.

 **Reference**

See p.97 "Security".

❖ **Security Timer**

Set the amount of time the machine waits before switching to the Higher Security mode.

 **Note**

- Default: *Off*

❖ **Display/Clear/Print Counter per User**

Allows you to view and print the various counters accessed with users and to set the values to 0.

 **Note**

- Press [**▲Prev.**] and [**▼Next**] to show all counters.
  - **Print Counter List**  
Prints the counter values for all the users.
  - **Clear All Counter**  
Sets the counter value of all users to 0.
  - **Clear Per User**  
Sets the counter value of a selected user to 0.

❖ **Program/Change/Delete User Code and Name**

You can register, change, or delete user codes and names.

 **Note**

- Up to 200 user codes (up to 4 digits) can be registered.

 **Reference**

p.162 "User Code".

❖ **Auto Delete File**

You can specify whether documents stored in the machine will be deleted or not after a specified period of time.

 **Note**

- Default: *No*
- If you select [**Yes**], documents stored subsequently will be deleted.
- If you select [**No**], documents will not be deleted automatically.
- If you select [**Yes**], enter a number of days in the range of 1 to 180.

❖ **Delete All Files**

All documents stored will be deleted.

 **Note**

- Even if a password has been set, all documents will be deleted.
- A confirmation dialog box will appear. To delete all documents, select [**Yes**].

❖ **Temporarily Unlock Stored Files**

Access to the files will be temporarily available without entering a password.

 **Note**

- Default: *Do not Unlock*
- Select [**Unlock**] only when you forget the password. After accessing the document, be sure to select [**Do not Unlock**].

## Master Making/Print Settings

### Reproduction Ratio

#### ❖ Shortcut Reduce/Enlarge 1–3

You can register up to three frequently used Reduce/Enlarge ratios other than the fixed Reduce/Enlarge ratio and have them shown on the initial display. You can also change registered Reduce/Enlarge ratios.

If no Reduce/Enlarge ratio has been set when selecting **[Shortcut Reduce / Enlarge 1]**, **[Shortcut Reduce / Enlarge 2]**, or **[Shortcut Reduce / Enlarge 3]**, enter the ratio using the number keys.

#### ❖ Enlarge 1–4

You can customize available enlargement ratios by pressing **[Reduce / Enlarge]**, followed by **[Enlarge]**.

##### Note

Default:

- Metric version:
  - Enlarge 1: 115%
  - Enlarge 2: 122%
  - Enlarge 3: 141%
  - Enlarge 4: 200%
- Inch version:
  - Enlarge 1: 121%
  - Enlarge 2: 129%
  - Enlarge 3: 155%
  - Enlarge 4: 200%

When selecting **[User Enlrg. Ratio]**, enter a ratio using the number keys (in the range of 101 to 200%).

#### ❖ Priority Setting:Enlarge

You can set the ratio with priority when **[Reduce / Enlarge]** is pressed, followed by **[Enlarge]**.

##### Note

Default:

- Metric version: 141%
- Inch version: 155%

#### ❖ Reduce 1–5

You can customize available reduction ratios by pressing **[Reduce / Enlarge]**, followed by **[Reduce]**

##### Note

Default:

- Metric version:
  - Reduce 1: 50%
  - Reduce 2: 61%
  - Reduce 3: 71%
  - Reduce 4: 82%
  - Reduce 5: 87%
- Inch version:
  - Reduce 1: 50%
  - Reduce 2: 65%
  - Reduce 3: 74%
  - Reduce 4: 77%
  - Reduce 5: 85%

When selecting **[User Redc.Ratio]**, enter a ratio using the number keys (in the range of 25 to 99%).

#### ❖ Priority Setting:Reduce

You can set the ratio with priority when **[Reduce / Enlarge]** is pressed, followed by **[Reduce]**.

##### Note

Default:

- Metric version: 71%
- Inch version: 74%

❖ **Ratio for Create Margin**

You can set a Reduce /Enlarge ratio when registering Create Margin in a shortcut key.

✎ **Note**

Default: 93%

❖ **Reduce/Enlarge Priority**

Specifies which tab has priority on the display panel when [**Reduce / Enlarge**] is pressed.

✎ **Note**

Default: *Reduce*

---

**Original Setting**

---

❖ **Master Making Density**

Specifies the image density at power on.

✎ **Note**

Default: *Normal*

❖ **Original Type**

Specifies the original type at power on.

✎ **Note**

Default: *Text*

❖ **Text/Photo Contrast**

Specify the contrast level for text/Photo when the power is switched on or after mode settings are cleared.

✎ **Note**

Default: *Normal*

❖ **Photo Contrast**

Specify the contrast level for Photo when the power is switched on or after mode settings are cleared.

✎ **Note**

Default: *Normal*

❖ **Photo (Screen)**

Specify the screen image in Photo mode when you press [**Original Type**]

✎ **Note**

Default: *Normal*

❖ **Background Correction**

When you make prints in Photo, Text/Photo, or Pale mode, the background of the prints might become dirty. You can select "On" to improve the clarity of your prints.

✎ **Note**

Default: *Off*

---

**Edit Setting**

---

❖ **Combine/Image Repeat Separation Line**

You can select a separation line using the Combine function from: None, Solid, Broken A, Broken B, or Crop Marks.

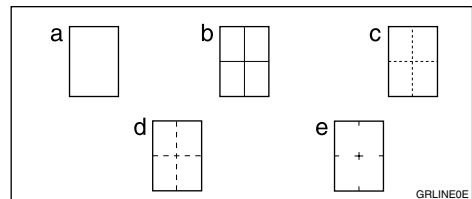

- a=None
- b=Solid
- c=Broken A
- d=Broken B
- e=Crop Marks

✎ **Note**

Default: *None*

❖ **Erase Original Border Width**

You can specify the width of erased border margins for originals using this function.

 **Note**

Default:

- Metric version: *2 mm*
- Inch version: *0.1"*

❖ **Erase Paper Border Width**

You can specify the width of erased border margins for prints using this function.

 **Note**

Default:

- Metric version: *2 mm*
- Inch version: *0.1"*

❖ **Stamp Type Defaults**

You can select the stamp message at power on with the Stamp mode.

 **Note**

Default: *CONFIDENTIAL*

❖ **Stamp Size**

You can edit the preset stamp sizes.

 **Note**

Default: *1 X*

❖ **Stamp Density**

You can select the density of the stamps.

 **Note**

Default: *Normal*

❖ **Stamp Position**

You can set the position where the stamp is printed.

Press the arrow keys to adjust the position.

 **Note**

Default:

- Metric Version:
  - Position: *Top Right*
  - Top Margin: *24 mm*
  - Right Margin: *24 mm*
- Inch Version:
  - Position: *Top Right*
  - Top Margin: *1.0"*
  - Right Margin: *1.0"*

---

**Others**

---

❖ **Ignore ADF Original Size**

When you place long originals in the optional ADF, set original detection to "Ignore". The machine will not detect the original size.

 **Note**

Default: *Do not Ignore*

❖ **Ignore Exposure Glass Original Size**

When you place custom sizes originals on the exposure glass, set original detection to "Ignore". The machine will not detect the original size.

 **Note**

Default: *Do not Ignore*

❖ **Cancel Combine/Repeat Setting**

Specifies whether Combine settings is cleared after finishing your print job.

 **Note**

Default: *Do not Cancel*

❖ **Auto Separate (Class)**

Specifies whether Separate mode is automatically selected when you make prints in Class Setting mode.

 **Note**

Default: *On*

❖ **Auto Rotation**

When the orientation in which your original is placed differs from that of the paper, the machine automatically rotates the original image by 90° to match the paper orientation.

 **Note**

Default: *On*

❖ **Minimum Print Quantity**

The minimum print quantity can be set between 0 and 9999.

Example: If you specify 20 as the minimum number of prints, runs of 20 or more prints will be accepted, print runs of less than 20 prints will not be accepted.

 **Note**

Default: *0 sheet(s)*

❖ **Maximum Print Quantity**

The maximum print quantity can be set between 0 and 9999.

 **Note**

Default: *9999 sheet(s)*

❖ **Economy Mode**

Specify the economy mode level of ink.

 **Note**

Default: *Off*

---

**Prog.Key Settings**

---

❖ **Function Key:F1–5**

You can assign frequently used functions to function keys F1 to F5.

 **Note**

Default:

- Function Key: F1: *1 Sided* → *1 Sided Combine: 2 originals*
- Function Key: F2: *1 Sided* → *1 Sided Combine: 4 originals*
- Function Key: F3: *Create Margin*
- Function Key: F4: *Off*
- Function Key: F5: *Off*

## User Code

If the machine has user codes set, users must enter their user code before they can use the machine. The machine keeps count of the number of masters and prints made under each user code.

### Note

- ❑ If you want to use this feature, select **[On]** in “User Code Management” with User Tools menu. See p.156 “User Code Management”.

## Registering a User Code

You can register up to 200 user codes.

- 1** Press the **[User Tools]** key.

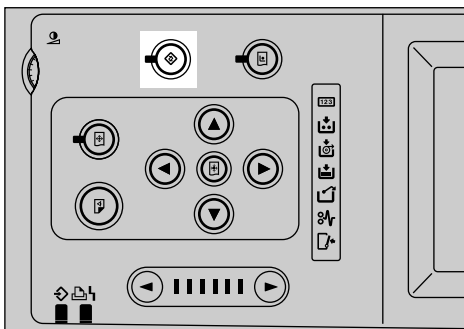

AJK135S

- 2** Press **[System Settings]**.
- 3** Press **[Administrator Tools]**.
- 4** Press **[Program / Change/ Delete User Code and Name]**.
- 5** Press **[New Program]**.

- 6** Enter the user code (up to four digits) using the number keys, and then press **[#]**.

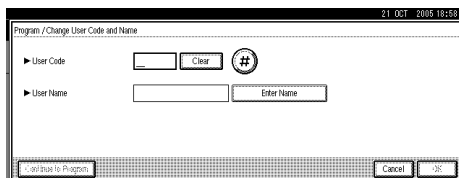

### Note

- ❑ If you make a mistake, press **[Clear]** or the **[Clear/Stop]** key, and then enter the code again.

- 7** Press **[Enter Name]**.

- 8** Enter the user name, and then press **[OK]**.

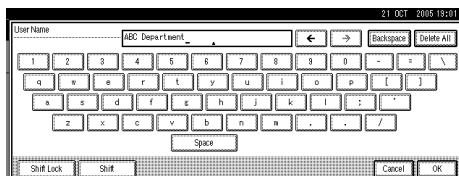

### Note

- ❑ To continue registering user codes and name, repeat the procedure from step **6**.

### Reference

p.175 “Entering Text”

- 9** Press **[OK]**.

- 10** Press **[Exit]**.

- 11** Press the **[User Tools]** key.

## Changing a User Code

### Note

- ❑ Even if you change a user code, the counter value will not be cleared.

- 1 Press the [User Tools] key.
- 2 Press [System Settings].
- 3 Press [Administrator Tools].
- 4 Press [Program / Change / Delete User Code and Name].
- 5 Select the registered user code you want to change.

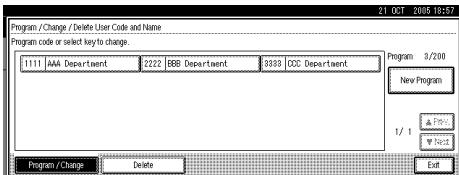

- 6 Enter the new user code and user name, and then press [OK].
- 7 Press [Exit].
- 8 Press the [User Tools] key.

## Deleting a User Code

### Note

- ❑ After clearing the user code, the counter is automatically cleared.

- 1 Press the [User Tools] key.
- 2 Press [System Settings].
- 3 Press [Administrator Tools].
- 4 Press [Program / Change / Delete User Code and Name].

- 5 Press [Delete].

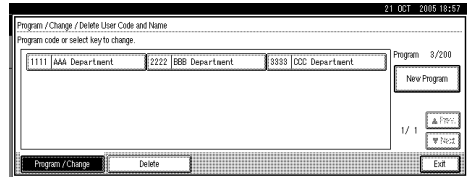

- 6 Select the user code you want to delete, and then press [OK].

### Note

- ❑ If you want to delete all user codes, press [Delete All].
- ❑ To delete all user codes on the page, press [All on The Page].

A confirmation dialog box will appear.

- 7 Press [Yes].
- 8 Press [Exit].
- 9 Press the [User Tools] key.

## Displaying the Counter for Each User Code

- 1 Press the [User Tools] key.
- 2 Press [System Settings].
- 3 Press [Administrator Tools].
- 4 Press [Display / Clear / Print Counter per User].

Counters of each user code appear.

## Printing the Counter for All User Codes

- 1 Press the [User Tools] key.
- 2 Press [System Settings].
- 3 Press [Administrator Tools].
- 4 Press [Display / Clear / Print Counter per User].
- 5 Press [Print Counter List].

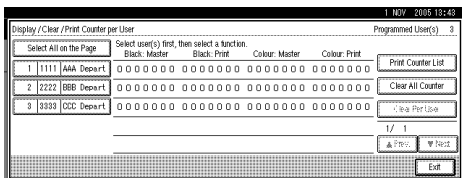

A confirmation dialog box will appear.

- 6 Press [Yes].

## Clearing the Counter

- 1 Press the [User Tools] key.
- 2 Press [System Settings].
- 3 Press [Administrator Tools].
- 4 Press [Display / Clear / Print Counter per User].

- 5 Select the user code to clear.

To clear the counter for each user code

- 1 Select the user code from the left side of the display.

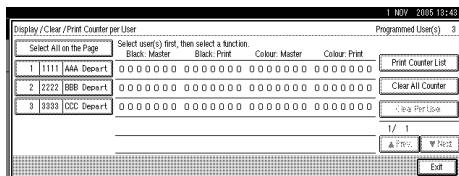

### Note

- Press [Select All on the Page] to select all user codes on the page.

- 2 Press [Clear Per User].

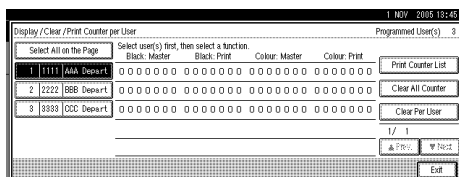

A confirmation dialog box will appear.

- 3 Press [OK].

To clear the counters for all user codes

- 1 Press [Clear All Counter].

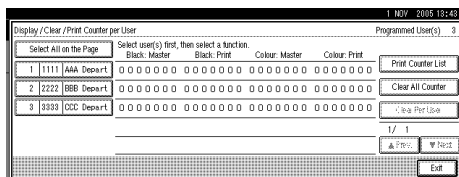

A confirmation dialog box will appear.

- 2 Press [OK].
- 6 Press [Exit].
- 7 Press the [User Tools] key.



## Do's and Don'ts

### **WARNING:**

- **Keep the machine away from flammable liquids, gases, and aerosols. A fire or an electric shock might occur.**

### **CAUTION:**

- *Unplug the power cord from the wall outlet before you move the machine. While moving the machine, you should take care that the power cord will not be damaged under the machine.*

### **Important**

- Make sure that the Data In  indicator is off before unplugging the power cord.
- While printing, do not turn off the main switch.
- While printing, do not unplug the power cord.
- While printing, do not open the door or covers.
- While printing, do not move the machine.
- Open and close all doors and covers carefully.
- When printing onto paper that contains images on the back, make sure there is a 6 mm (0.24") margin at the back leading edge. If there is no margin, the machine might wrongly detect that paper is wrapped around the drum and stop printing.
- When you use envelopes or pasted print paper, the leading edge of the prints might be damaged.
- Always make a few trial prints to check the image position because the image position of the trial print might not correspond with that of the original.
- The leading edge of the prints might become stained if the edge touches the image of prints on the paper delivery tray.
- Print ink on the paper delivery tray might stick to the back side of the next print.
- Press the **[Proof]** key to perform a test print as the image density of the first few prints might be light.
- When the machine is on and the power source is less than 90% of the specified amount, printing quality will decrease. Therefore, make sure the supply from your electrical outlet is at least 90% of the required amount.
- When you make a lot of prints from a small image, ink might ooze out from the edges of the master, especially in high temperatures and when printing in two or more colours. In these cases, make a new master.

- Remove the paper from the tray before relocating the machine. If you relocate the machine leaving the paper on the tray, reset the paper after the relocation. If the main switch of the machine is turned on without resetting the paper correctly, the sensor might be broken.
- If the printed paper is stored for more than one day, the paper may become wrinkled. If this paper is used, wrinkles may also appear on the master. If the paper will be stored for more than one day, store it in its original wrapping paper or other protective covering.
- Shadowing may occur if the printed image at the rear edge of the paper is a solid colour, when the printing speed is set to 1. If this occurs, print the image with the printing speed set to 3.
- If there are fine lines within 5 mm to 10 mm, 0.2" to 0.4" of the edge of the image, shadowing may occur.
- Depending on the type of paper being used, speckles may appear within 5 mm to 10 mm, 0.2" to 0.4" of the edge of the image at around 1000 prints.
- When two or more sheets of paper feed at once, you can select whether the warning message is displayed or not. Set to "On" of the "Double Feed Warning" with User Tools. See p.156 "Double Feed Warning".
- When two or more sheets of paper feed at once, set paper on the paper feed side plates securely. See p.31 "Using the Paper Feed Tray and Delivery Tray"
- When paper misfeeds occur, select the proper paper type from **[Feed Tray Paper Type]**. See p.47 "Printing onto Various Kinds of Paper". If the problem persists, fan or turn the paper over.
- If the paper skews, make sure to set the paper feed side plates securely. See p.31 "Using the Paper Feed Tray and Delivery Tray".
- Make sure originals on the exposure glass are correctly positioned and aligned with the scale.
- If the edges of the paper are rounded, skewing might occur. Change the paper's orientation or replace.
- If the paper becomes creased, make sure the correct paper type has been selected in **[Feed Tray Paper Type]**. See p.47 "Printing onto Various Kinds of Paper".
- If custom paper crease frequently, use the standard paper type.

# Where to Put Your Machine

---

## Machine Environment

---

Your machine's location should be carefully chosen because environmental conditions greatly affect its performance.

---

### Optimum environmental conditions

---

**⚠ CAUTION:**

- *Keep the machine away from humidity and dust. Otherwise a fire or an electric shock might occur.*
- *Do not place the machine on an unstable or tilted surface. If it topples over, an injury might occur.*

**⚠ CAUTION:**

- *If you use the machine in a confined space, make sure there is a continuous air turnover.*

**⚠ CAUTION:**

- *After you move the machine, use the caster fixture to fix it in place. Otherwise the machine might move or come down to cause an injury.*

- Temperature: 10 – 30°C, 50 – 86°F
- Humidity: 20 – 90% RH
- A strong and level floor.
- The machine must be level within 5 mm, 0.2" both front to rear and left to right.

---

### Environments to avoid

---

- Locations exposed to direct sunlight or strong light (more than 1500 lux).
- Locations directly exposed to cool air from an air conditioner or heated air from a heater (sudden temperature changes might cause condensation within the machine).
- Places where the machine might be subjected to frequent strong vibration.
- Dusty areas.
- Areas with corrosive gases.

---

## Moving

---

**⚠ CAUTION:**

- *Unplug the power cord from the wall outlet before you move the machine. While moving the machine, you should take care that the power cord will not be damaged under the machine.*

**🔊 Important**

- ❑ When moving the machine, the following precautions should always be followed:
  - Turn off the main switch.
  - Unplug the power cord from the wall outlet. When you do, grip the plug to avoid damaging the cord and causing fire or electric shock.
  - Close all covers and trays including the front cover.

**💡 Limitation**

- ❑ Carefully move the machine. If you do not, the machine might be damaged or a stored file might be deleted.
- ❑ Avoid any strong shock to the machine. This could damage the hard disk and cause stored files to be deleted. For precautionary reasons, files should be copied to another local computer.

---

## Power Connection

---

**⚠ WARNING:**

- ***Connect the power cord directly into a wall outlet and never use an extension cord.***
- ***Only connect the machine to the power source describe in the manual.***
- ***Do not damage, break or make any modifications to the power cord. Do not place heavy objects on it. Do not pull it hard nor bend it more than necessary. These actions could cause an electric shock or fire.***

**⚠ CAUTION:**

- *Unplug the power cord from the wall outlet before you move the machine. While moving the machine, you should take care that the power cord will not be damaged under the machine.*

**⚠ CAUTION:**

- *When you disconnect the power plug from the wall outlet, always pull the plug (not the cable).*

- The socket-outlet shall be installed near the machine and shall be easily accessible.
- Voltage must not fluctuate more than 10%.

## Access to the Machine

Place the machine near the power source, providing the clearance areas as shown.

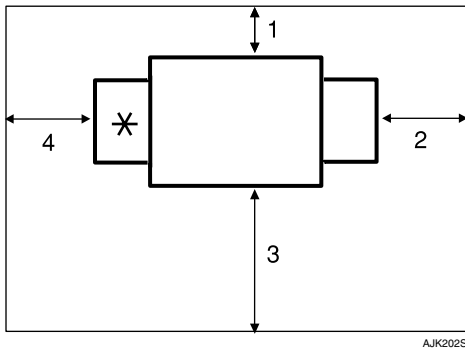

\* Paper delivery tray

1. More than 10 cm, 4.0"
2. More than 60 cm, 23.7"
3. More than 60 cm, 23.7"
4. More than 60 cm, 23.7"

### Note

- For the required space when options are installed, contact your service representative.

# Maintaining Your Machine

To maintain high print quality, clean the following parts and units regularly.

## ❖ Cleaning the machine

Wipe the machine with a soft, damp cloth. Then wipe it with a dry cloth to remove the water.

## ⚠ Important

- ❑ Do not use chemical cleaner or organic solvents, such as thinner or benzene. If they get into the machine or melt plastic parts, a failure might occur.
- ❑ Do not clean parts other than those specified in this manual. Such parts should be cleaned by your service representative.

6

## Cleaning the Exposure Glass

**1** Lift the exposure glass cover or ADF.

**2** Clean ① and ②.

### 📌 Note

- ❑ When using the exposure glass, clean ② only.

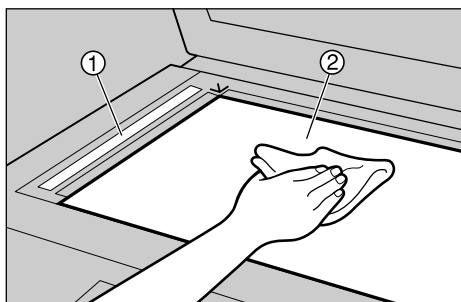

ZDCH130E

## Cleaning the exposure glass cover

**1** Lift the exposure glass cover.

**2** Clean the exposure glass cover with a damp cloth and wipe it with a dry cloth.

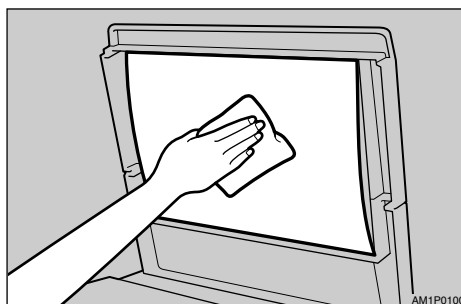

AM1P0100

### 📌 Note

- ❑ If you do not clean the exposure glass cover, marks on the cover will be printed.

## Cleaning the Auto Document Feeder

- 1** Lift the ADF.
- 2** Clean the sheet with a damp cloth and wipe it with a dry cloth.

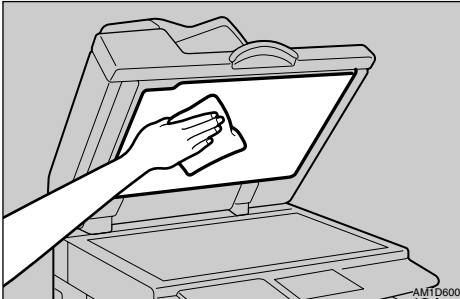

**Note**

- If you do not clean the sheet, marks on the sheet will be printed.

## Cleaning the paper feed roller (LCIT)

- 1** Wipe dust off the paper feed roller with a damp cloth, and then wipe it with a dry cloth.

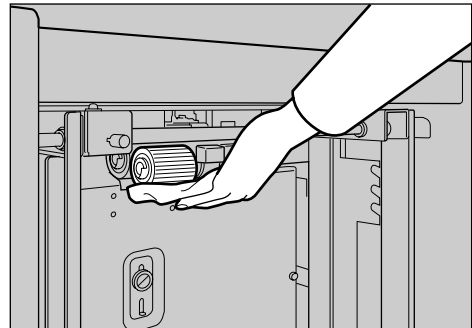

**Note**

- Keep the paper feed roller clean to avoid paper misfeeds.

## Cleaning the paper feed roller (paper feed tray)

- 1** Wipe dust off the paper feed roller with a damp cloth, and then wipe it with a dry cloth.

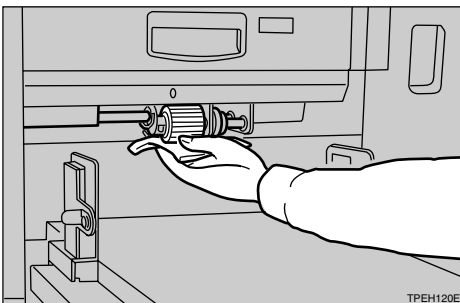

**Note**

- If you do not clean the paper feed roller, paper misfeeds tend to occur.

# Other Functions

## Inquiry

The inquiry functions lets you confirm the telephone numbers to contact for repairs or to order ink. Be sure to contact your service engineer to verify the following:

### ❖ Machine Maintenance/Repair

- Telephone No.
- Serial No. of Machine

### ❖ Sales Representative

- Telephone No.

## 1 Press the [User Tools] key.

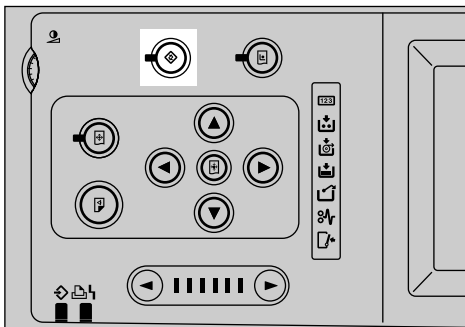

AJK135S

## 2 Press [Enquiry].

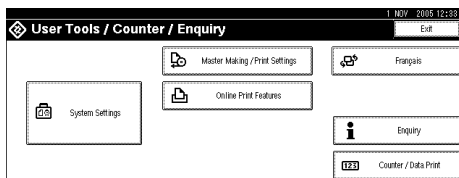

Enquiry information is displayed.

## Printing Enquiry information

### 1 Press [Print Enquiry List].

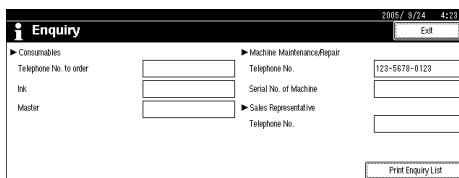

### 2 Press the [Start] key.

Enquiry information is printed.

### 3 Press [Exit].

### 4 Press [Exit].



## Changing the Display Language

You can change the language used on the display. English is set as default setting.

**1** Press the **[User Tools]** key.

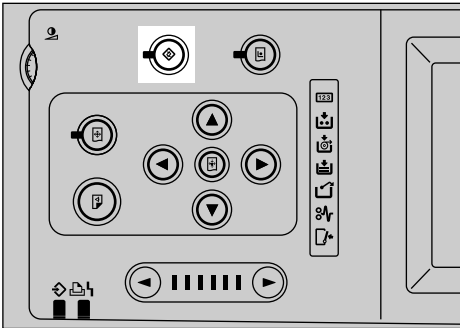

AJK135S

**2** Press **[Français]**.

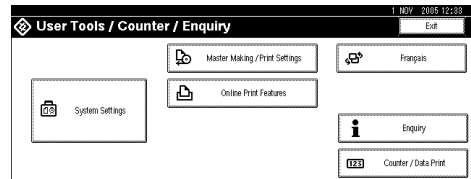

The display language is changed to French.

**3** Press **[Sortie]**.

The menu appears in French.

### Note

- If you want to return the display language to “English”, repeat step **1** and press **[English]**.

# Counter/Data Print

## Displaying the Counter

Display the number of sheets used for master making and the number of sheets used for printing.

Two types of counter can be displayed.

You can check the number of total sheets using counter, and check the number of sheet after resetting.

You can also reset the resettable counter.

**1** Press the **[User Tools]** key.

**2** Press **[Counter / Data Print]**.

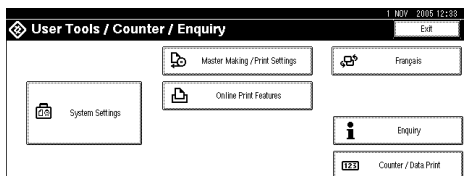

## Reset the Counter

**1** Press **[Clear]** below the master making figures and print figures in the resettable counter area.

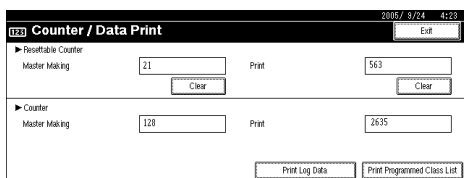

## Print the log data and programmed class list

Print the log data or programmed class list.

### ❖ Log Data

Check the making master and print log data.

### ❖ Program Class List

Check the programmed class registered in the Class Settings function.

### 🔍 Reference

p.67 "Class Settings"

**1** Press the **[User Tools]** key.

**2** Press **[Counter / Data Print]**.

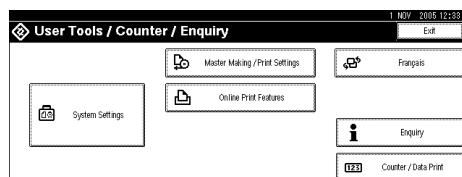

**3** To print a log data, press **[Print Log Data]**.

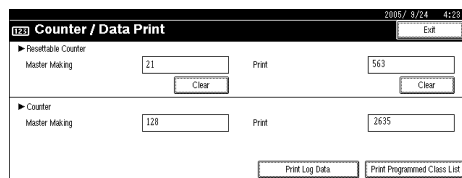

### 📌 Note

❑ When you need the programmed class list, press **[Print Programmed Class List]**.

**4** Press **[Yes]**.

# 7. Entering Text

## Entering Text

This section describes how to enter characters. When you enter a character, it is shown at the position of the cursor. If there is a character at the cursor position, the entered character is shown before that character.

---

### Available Characters

---

- Alphabetic characters  
ABCDEFGHIJKLMNOPQRSTUVWXYZabcdefghijklmnopqrstuvwxyz
- Symbols
- Numerals  
0123456789

---

### Keys

---

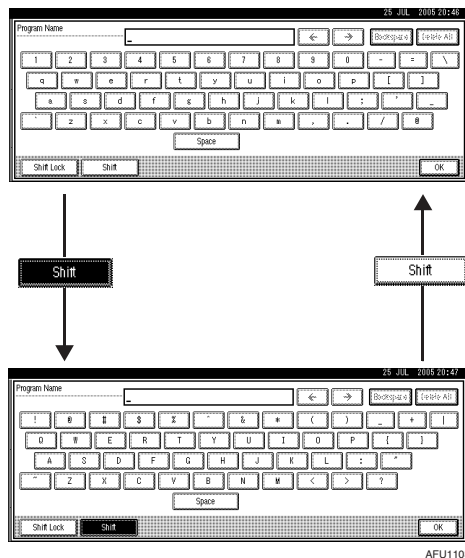

#### Note

- ❑ When entering uppercase or lowercase letters continuously, use **[Shift Lock]** to lock the case.

---

## Entering Text

---

---

### Entering letters

---

- 1** Press [Shift] to switch between uppercase and lowercase.
  - 2** Press the letters you want to enter.
- 

### Deleting characters

---

- 1** Press [Backspace] or [Delete All] to delete characters.

# 8. Specifications

## Main Unit

- ❖ **Configuration:**  
Floor standing
- ❖ **Printing Process:**  
Full automatic one drum system
- ❖ **Original Type:**  
Sheet/Book
- ❖ **Original Size:**  
Maximum 300 mm × 432 mm, 11.8" × 17.0"
- ❖ **Pixel Density:**  
600 × 600 dpi (dots per inch)
- ❖ **Image Mode:**  
Text mode  
Text/Photo mode  
Photo mode  
Pencil mode  
Pale mode
- ❖ **Reduction Ratios:**
  - Metric version:  
93%, 87%, 82%, 71%, 61%, 50%
  - Inch version:  
93%, 85%, 77%, 74%, 65%, 50%
- ❖ **Enlargement Ratios:**
  - Metric version:  
141%, 122%, 115%
  - Inch version:  
155%, 129%, 121%
- ❖ **Zoom:**  
From 50% to 200% in increments of 1%
- ❖ **Directional Magnification:**
  - Vertical:  
From 50% to 200% in increments of 1%
  - Horizontal:  
From 50% to 200% in increments of 1%

❖ **Printing Area:**

- Metric version:
  - A3 drum: more than 290 × 412 mm, 11.4" × 16.3"
  - A4 drum: more than 290 × 202 mm, 11.4" × 8.0"
- Inch version:
  - 11" × 17" drum: more than 290 × 422 mm, 11.4" × 16.7"
  - A4 drum: more than 290 × 202 mm, 11.4" × 8.0"

❖ **Print Paper Size:**

Maximum recommended: 297 mm × 432 mm, 11.6" × 17.0" (Maximum: 325 mm × 447 mm, 12.8" × 17.6")

Minimum: 70 mm × 148 mm, 2.8" × 5.8"

❖ **Leading Edge Margin:**

Less than 6 mm, 0.24"

❖ **Print Paper Weight:**

- 47.1 – 209.3 g/m<sup>2</sup>, 12.5 – 55.6 lb

❖ **Print Speed:**

Paper length of 364 mm, 14.4" or more: 60 – 120 cpm (5 increments)

Paper length of less than 364 mm, 14.4": 60 – 135 cpm (6 increments)

❖ **First print Time (Master Process Time):**

Less than 28 seconds (A3, 11" × 17" )

Less than 20 seconds (A4, 8<sup>1</sup>/<sub>2</sub>" × 11" )

❖ **Colour Printing:**

Drum unit replacement system

❖ **Image Position:**

- Vertical:
  - Inch version: ± 10 mm, ± 0.4"
  - Metric version: ± 15 mm, ± 0.6"
- Side:
  - ± 10 mm, ± 0.4" (for either side)

❖ **Paper Size and Paper Capacity:**

1,000 sheets (80 g/m<sup>2</sup>, 20 lb)

❖ **Paper Delivery Tray Capacity:**

1,000 sheets (80 g/m<sup>2</sup>, 20 lb)

❖ **Master Eject Unit Capacity:**

- A3 drum  
More than 100 masters
- 11" × 17" drum  
90 masters
- A4 drum  
140 masters

❖ **Dimensions (W × D × H)**

	Width	Depth	Height
Stored	750 mm, 29.5"	700 mm, 27.6"	585 mm, 23"
Stored with ADF	750 mm, 29.5"	700 mm, 27.6"	695 mm, 27.4"
Set up	1420 mm, 55.9"	700 mm, 27.6"	585 mm, 23"
Set up with cabinet	1420 mm, 55.9"	700 mm, 27.6"	1020 mm, 40.2"
Set up with cabinet and ADF (when you use A3, 11" × 17" or larger paper)	1420 mm, 55.9"	700 mm, 27.6"	1130 mm, 44.5"

❖ **Weight:**

- Machine:  
Less than 104 kg, 229.3 lb

❖ **Noise Emission <sup>\*1</sup>**

Sound power level

	Printing speed	Noise emission
Stand-by	--	38dB (A)
During printing	135 cpm	81dB (A)

Sound pressure level <sup>\*2</sup>

	Printing speed	Noise emission
Stand-by	--	22dB (A)
During printing	135 cpm	67dB (A)

<sup>\*1</sup> The above measurements made in accordance with ISO 7779 are actual value.<sup>\*2</sup> It is measured at the position of the operator.❖ **Power Consumption:**

- Making a master:  
Less than 0.34 kW
- Printing:  
Less than 0.27 kW (when printing speed is 135 cpm)

# Options

---

## Auto Document Feeder (ADF: DF Type 85)

---

❖ **Original Type:**

Sheet

❖ **Original Weight:**

52.3 g/m<sup>2</sup> to 127.9 g/m<sup>2</sup>, 13.9 lb to 34 lb

❖ **Original Size:**

Max. 297 mm × 864 mm, 11.7" × 34.0"

Min. 149 mm × 210 mm, 5.9" × 8.3"

❖ **First print Time:**

Less than 33 seconds (A3, 11" × 17")

Less than 25 seconds (A4, 8<sup>1</sup>/<sub>2</sub>" × 11")

❖ **Original Capacity:**

50 sheets (80 g/m<sup>2</sup>, 20 lb)

7.5 mm, 0.3" height



## Twin Colour Press Roller Printing System TC-IIR

### ❖ Configuration:

Floor standing

### ❖ Printing Process:

Twin colour press roller printing system

### ❖ Print Paper Size:

Maximum: 297 mm × 432 mm, 11.6" × 17.0"

Minimum: 70 mm × 250 mm, 2.8" × 9.8"

### ❖ Print Paper Weight:

- 52.3 – 209.3 g/m<sup>2</sup>, 13.9 – 55.6 lb

### ❖ Print Speed:

90 – 120 cpm (3 increments)

### ❖ Colour Printing:

Drum unit replacement system

### ❖ Paper Size and Paper Capacity:

1,000 sheets (80 g/m<sup>2</sup>, 20 lb)

### ❖ Paper Delivery Tray Capacity:

1,000 sheets (80 g/m<sup>2</sup>, 20 lb)

### ❖ Dimensions (W × D × H)

	Width	Depth	Height
Stored	920 mm, 36.2"	630 mm, 24.8"	555 mm, 21.9"
Set up	1,610 mm, 63.4"	630 mm, 24.8"	555 mm, 21.9"

### ❖ Weight:

- Machine:  
Less than 88 kg, 194 lb

### ❖ Power Consumption:

- Printing:  
0.55kW(Max)

### ❖ Optional Equipment:

- Drum unit:  
Metric version: Drum Type 90 <A3> / <A4>  
Inch version: Drum Type 90 <A4> (8<sup>1</sup>/<sub>2</sub>" × 11") / <11" × 17">

### Note

- ❑ Specifications are subject to change without notice.

## Large Capacity System (LCS: LS3000R)

### ❖ Configuration:

Optional large paper capacity system

### ❖ Paper type:

Corresponds to the machine specification

### ❖ Printing paper size:

- LCIT:

Maximum 297 × 432 mm, 11.6" × 17.0" (325 × 447 mm, 12.7" × 17.5" <sup>\*1</sup>)  
 Minimum 128 × 182 mm, 5.1" × 7.1"

- LCOT:

Maximum 297 × 432 mm, 11.6" × 17.0" (325 × 447 mm, 12.7" × 17.5" <sup>\*1</sup>)  
 Minimum 70 × 148 mm, 2.8" × 5.9" (When the LCIT is installed: 128 × 182 mm, 5.1" × 7.1" )

<sup>\*1</sup> When the image position is set to 0 mm (0").

### ❖ Print paper weight:

47.1 – 209.3 g/m<sup>2</sup>, 12.5 – 55.61 lb.

### ❖ Feed tray capacity:

3000 sheets (80 g/m<sup>2</sup>, 20 lb.)

Paper stack height: Less than 320 mm (12.5")

### ❖ Output tray capacity:

3000 sheets (80 g/m<sup>2</sup>, 20 lb.)

Paper stack height: Less than 345 mm (13.5")

### ❖ Print speed:

Corresponds to the machine specification

### ❖ Power consumption:

Standby	Less than 25 W
Printing	Less than 88 W

### ❖ Dimensions (W×D×H):

- LCIT: 968 × 545 × 778 mm (38.1" × 21.4" × 30.6")

- LCOT: 560 × 512 × 778 mm (22" × 20.1" × 30.6")

### ❖ Weight:

- LCIT: Less than 45 kg, 99 lb.

- LCOT: Less than 30 kg, 66 lb.

---

## Other Options

---

- Drum Unit  
Metric version: Drum Type 90 <A3> / <A4>  
Inch version: Drum Type 90 <A4> (8<sup>1</sup>/<sub>2</sub>" × 11") / <11" × 17">
- Platen Cover Type 1018
- Key Counter
- PostScript3 Board Type 2
- IEEE 1284 Parallel Board Type 1
- IEEE 802.11b I/F Unit Type 1
- Memory Unit TypeC (128 MB/256 MB)
- Extension HDD Type 1

# Consumables

Name	Size	Remarks
Master:	Length: 110 m, 410 ft/roll Width: 320 mm, 12.6" 2 rolls/case	A3 drum More than 200 masters can be made per roll 11" × 17" drum 190 masters can be made per roll A4 drum 320 masters can be made per roll
Ink-Black	1,000ml/pack	Environmental conditions: -5 to 40°C 10 – 95% RH
Ink-Red	1,000ml/pack	
Ink-Blue		
Ink-Green		
Ink-Brown		
Ink-Purple		
Ink-Yellow		
Ink-Navy		
Ink-Maroon		
Ink-Teal		
Ink-Orange		
Ink-Gray		
Ink-Violet		
Ink-Hunter green		
Ink-Burgundy		
Ink-Gold		
Ink-Reflex Blue		

 **Note**

Specifications are subject to change without notice.

# INDEX

---

2 one-sided originals, 63

4 one-sided originals, 63

## A

---

Adding ink, 126

ADF, 15

Adjusting

*the position of printed images, 54*

Administrator Tools, 156

Auto

*reduce/enlarge, 59*

Auto Cycle key, 17

Auto Document Feeder, 13, 15

Auto off mode, 46

Auto Off Timer, 153

Auto off timer, 46

auto paper select, 25

Auto quality start, 95

## B

---

background patterns, 84

Basic procedure, 44

Black line/stain, 119

Buffer fins, 13

## C

---

Changing

*Display Language, 173*

*File Name, 102*

*Password, 102*

*program, 107*

*program name, 107*

*stamp position, size and density, 81*

*User Name, 102*

Changing a user code, 163

Changing the Paper Size of LCIT

*Changing the Paper Size, 142*

Changing the Paper Size of the Paper Feed Tray

*Changing the Paper Size, 141*

Changing the printing speed, 55

Checking Stored Files, 103

Check Modes key, 17

Chocks, 12, 33

Clearing misfeeds, 130

Clearing the number of prints, 164

Clear Modes key, 17

Clear/Stop key, 18

closed area method, 89

Colour drum, 109

Combination chart, 114

Combine, 63

command sheet, 85

Common key operations, 20

Consumables, 184

Control panel, 11, 17

Copier functions

*margin adjustment, 77*

Counter

*Displaying, 174*

Cover, 15

Cover release lever, 15

Custom repeat, 75

## D

---

Data In indicator (Green), 18

Deleting

*program, 108*

Deleting a user code, 163

diagonal line method, 88

Dirty background, 119

Disabling normal security, 97

Displaying

*Counter, 174*

Displaying the Counter for each user code, 163

Display Language

*Changing, 173*

Display panel, 19

Double feed, 99

Down button, 15, 16

Drum size, 113

Drum unit, 12

Drum unit handle B2, 109

Drum unit lock lever B1, 12

## E

---

Economy mode, 96

Edge erase, 76

End plate, 16

End plate screw, 16

Energy saver mode, 46

Energy Saver Timer, 153

Entering Text, 175

Envelopes, 47

Error indicator (Red), 18

Exposure glass, 12

Exposure glass cover, 13

## F

---

- Feeding pressure lever, 15, 145
- File Name
  - Changing*, 102
- Front door, 11

## G

---

- General Features, 153
- Guide to Components, 11

## H

---

- Higher security, 97
- Hold Data-in key, 17

## I

---

- Image position key, 17
- Image rotation, 51
- Indicators, 15, 17
- Initial position key, 18
- Ink, 126, 184
- Ink holder, 12
- Input tray, 15
- Inquiry, 172
- Intermediate feeding section, 15

## L

---

- Large capacity input tray, 15
- Large capacity output tray, 16
- Large Capacity System, 15, 16
- LCIT, 15
  - Installing the LCIT*, 34
  - Loading Paper*, 36
  - Uninstalling the LCIT*, 41
- LCIT release lever, 15
- LCOT, 16
  - Paper alignment wings*, 37
  - Setting up the LCOT*, 36
- LCS, 15
- Loading paper, 31, 124

## M

---

- Machine environment, 167
- Main power indicator, 17
- Main switch, 12, 21
- Maintaining your machine, 170
- Make-Up, 82
- Make-Up printing, 92
- Make-Up samples, 93
- Master, 184
- Master eject indicator, 144

- Master eject unit handle E1, 12
- Master length, 98
- Master Making mode select key, 17
- Master making unit, 11
- Master misfeeds
  - in the master eject section*, 137, 138
  - in the master feed section*, 135, 136
- Mode Setting, 154

## N

---

- Normal security, 97
- Number keys, 18

## O

---

- Open Cover/Unit indicator, 143
- Operation switch, 18
- Options, 14, 180
- Original
  - orientation*, 42
- Original misfeeds, 139
- Originals, 23
- Original Type, 52
- Output tray, 16

## P

---

- Pale
  - Original Type*, 52
- Panel Beeper, 153
- Paper
  - Recommended for the LCIT*, 26
  - Recommended for the LCOT*, 27
- Paper alignment wings, 12, 33
- Paper delivery end plate, 12
- Paper delivery end plate knob, 13
- Paper delivery side plate knobs, 13
- Paper delivery side plates, 12
- Paper delivery tray, 12
- Paper feed side plates, 11
- Paper feed side plates knob, 11
- Paper feed side plates knob lock lever, 11
- Paper feed tray, 11
- Paper feed tray down key, 11
- Paper misfeeds
  - in the LCIT*, 140
  - in the paper feed section*, 130, 131
- Paper misfeeds in the paper exit section, 135
- Paper or master wrapped around the drum, 132
- Paper type, 47, 48
- Password
  - Changing*, 102
  - Setting or changing*, 102

Pencil  
    *Original Type*, 52

Photo  
    *Original Type*, 52

Placing  
    *originals*, 43  
    *originals in auto document feeder*, 43  
    *originals on exposure glass*, 43

Position Setting keys, 17

Power connection, 168

Power Switch, 35

Power switch, 15

Preset Reduce/Enlarge, 57

Preset stamp  
    *changing density*, 81  
    *changing position*, 81  
    *changing size*, 81  
    *position and original orientation*, 80

Printer functions  
    *Auto reduce/enlarge*, 59  
    *directional magnification (%)*, 61  
    *zoom*, 58

Printer Settings key, 17

Printing Functions, 57

printing functions  
    *centring*, 76  
    *directional size magnification (mm)*, 62

Printing in two colours, 111

Printing Size, 30

Printing the Counter for each user code, 164

Printing the First Page, 104

Print key, 17

Print paper, 26

Program key, 17

Programs, 106

Proof key, 17, 18

Protecting  
    *program*, 107

## Q

---

Quality start, 95

## R

---

Recalling a program, 107

Registering a user code, 162

Remarks, 165

Removing the used master, 144

Repeat, 73

Replacing master roll, 128

## S

---

Safety information, 8

Saving energy, 46

Screen contrast knob, 17

Security, 97

Service call, 118

Set Date, 153

Set Time, 153

Setting or changing  
    *Password*, 102

Setting up the paper delivery tray, 32

Side guide adjustment knob, 15, 16

Side guides, 15, 16

Side guide screw, 15

Size and Weights of Recommended  
    Originals, 23

Sizes difficult to detect, 25

Skip feed, 96

Special paper, 48

Specifications, 177

Speed setting keys, 18

Standard paper, 47

Start key, 18

Storing  
    *program*, 106

System Auto Reset Timer, 153

System Settings, 147

## T

---

Text  
    *Deleting*, 176  
    *Entering*, 176  
    *Original Type*, 52

Text/Photo  
    *Original Type*, 52

Thick paper, 47

Timer Settings, 153

Trailing edge guides, 13

Troubleshooting, 117

Turning Off the Power, 21

Turning On the Power, 21

## U

---

Up button, 15, 16

User Code, 162

User Name  
    *Changing*, 102

User Tools, 147  
    *Changing defaults*, 152  
    *Quitting User Tools*, 152

User Tools key, 17

## W

---

Web browser

*Storing files*, 105

What you can do with this machine, ii

When the image density is too light, 119

Where to put your machine, 167



## Symbols

In accordance with IEC 60417, this machine uses the following symbols for the main switch:

**I** means **POWER ON.**

**O** means **POWER OFF.**



### Declaration of Conformity

“The Product complies with the requirements of the EMC Directive 89/336/EEC and its amending directives and the Low Voltage Directive 73/23/EEC and its amending directives.”

### Notice To Wireless LAN Interface (optional) Users (if applicable)



### Notice to Users in EEA Countries

This product complies with the essential requirements and provisions of Directive 1999/5/EC of the European Parliament and of the Council of 9 March 1999 on radio equipment and telecommunications terminal equipment and the mutual recognition of their conformity.

The CE Declaration of Conformity is available on the Internet at URL:

[http://www.ricoh.co.jp/fax/ce\\_doc/](http://www.ricoh.co.jp/fax/ce_doc/)

Outdoor use of this product is prohibited in France and Italy.

# Operating Instructions

